



Universalspülmaschinen

Universal dishwashers

Universal lave-vaisselle



UXT / UPT

Ab Serien-Nummer:
Starting from Serial No.:
A partir du no. de série:

8664 0000

ERSATZTEILE

SPARE PARTS

PIECES DETACHEES

REV. 04.05.2012



PLATON SERVICE

8 (800) 500-34-47

www.platonservice.com

Die in diesem Katalog aufgeführten Elektroteile beziehen sich auf folgende Spannungen:

Electrical components listed in this catalogue are rated for the following supply voltages:

Les composants électriques énumérés dans ce catalogue sont prévus pour les tensions suivantes:

230V / 50Hz / 1 / PE
400V / 50Hz / 3 / N

Bei nicht aufgeführten elektrischen Komponenten bitte den, der Maschine beigelegten, Schaltplan beachten.

For non listed electrical parts, refer to the wiring diagram shipped with the machine.

Pour les composants électriques non émunérés, se référer au schéma électrique envoyé avec la machine.

INHALT

Tank und Untergestell	6
Türen	12
Verkleidungen	14
Siebsystem	16
Füllung - ohne Enthärter	18
Füllung - ohne Enthärter ab Serien-Nummer 8664 1621	20
Separate Füllung	22
Separate Füllung ab Serien-Nummer 8664 1621	26
Waschpumpe	28
Boiler	30
Wasch- und Spülsystem	34
Wascharme	38
Wasch- und Spülsystem - seitlich	40
Wasch- und Spülsystem - seitlich (Schläuche, Frontansicht links)	44
Wasch- und Spülsystem - seitlich (Schläuche, Frontansicht rechts)	48
Dosiergeräte	52
Schaltkasten	54
Abwasser - Wärmerückgewinnung	56
Abluft - Wärmerückgewinnung	58
Körbe	62

**CONTENT**

Tank and support	6
Doors	12
Panels	14
Strainer system	16
Fill - without softener	18
Fill - without softener starting from Serial No. 8664 1621	20
Separate filling	22
Separate filling starting from Serial No. 8664 1621	26
Wash pump	28
Booster	30
Wash and rinse system	34
Wash arm	38
Wash and rinse system - lateral	40
Wash and rinse system - lateral (Hoses, front view left)	44
Wash and rinse system - lateral (Hoses, front view right)	48
Dispensers	52
Control box	54
Drain - heat recovery	56
Exhaust - heat recovery	58
Racks	62

SOMMAIRE

Bac et socle.....	6
Portes	12
Panneaux	14
Système de filtre	16
Remplissage - sans adoucisseur.....	18
Remplissage - sans adoucisseur a partir du no. de série 8664 1621	20
Séparée de remplissage	22
Séparée de remplissage a partir du no. de série 8664 1621	26
Pompe de lavage.....	28
Chaudière.....	30
Système de lavage et de rinçage	34
Bras de lavage.....	38
Système de lavage et de rinçage - latéral	40
Système de lavage et de rinçage - latéral (Tuyaux, vue avant gauche)	44
Système de lavage et de rinçage - latéral (Tuyaux, vue avant droite)	48
Dosseurs.....	52
Panneau de commande.....	54
Récupération - de chaleur vidange.....	56
Air extrait - récupération de chaleur vapeur	58
Paniers.....	62



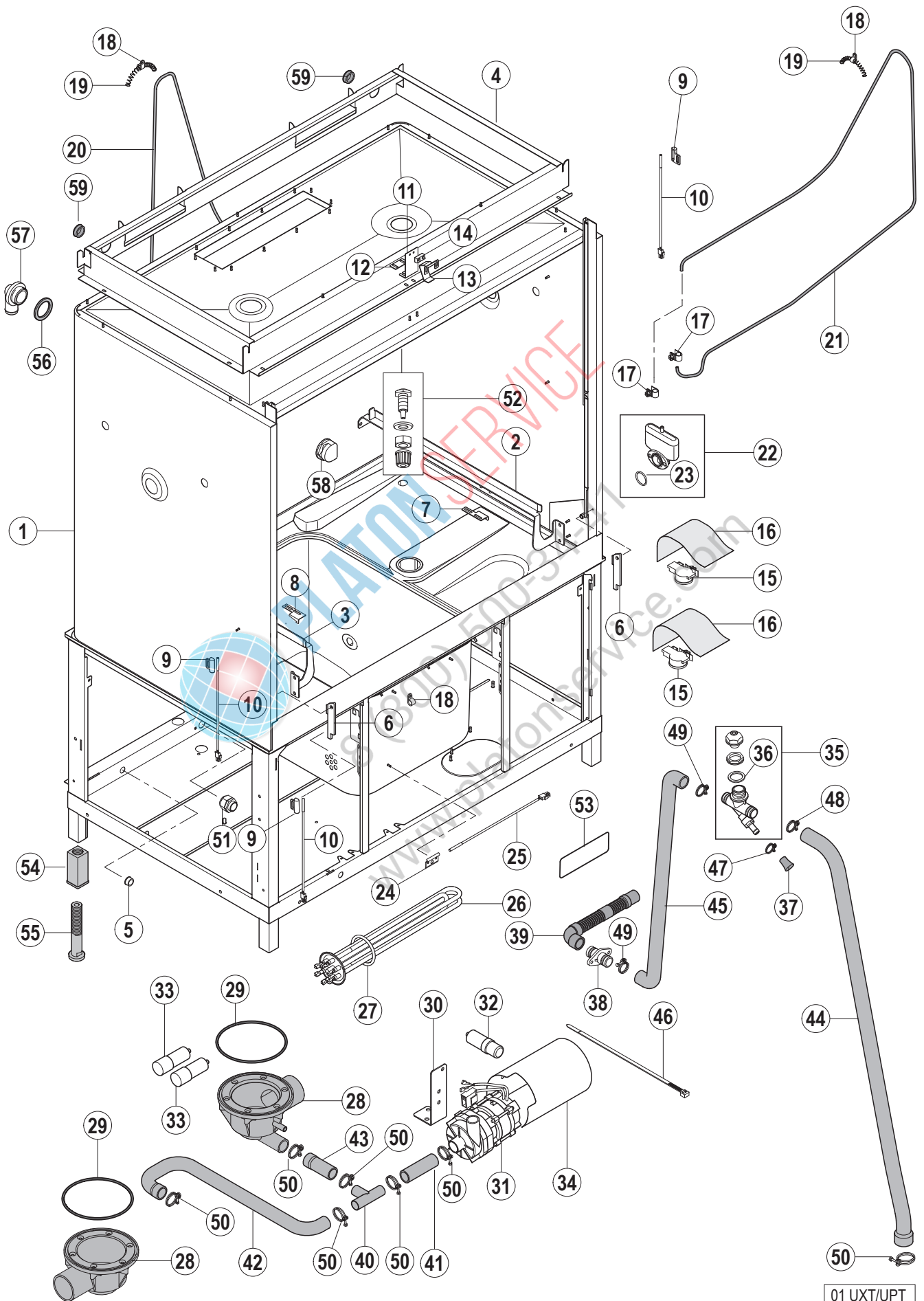

01 UXT/UPT

Pos.-Nr. Key no. Réf.	Teile-Nr. Part no. No. pièce	Teile-Benennung Part name Nom de la pièce	Bemerkungen Remarks Remarques
01	01-294842-004	Unterbau Basement Châssis	UXT
	01-294842-006	Unterbau Basement Châssis	UPT
02	01-294924-001	Korbführung, rechts Rack guide, right Guides casiers, droite	
03	01-294924-002	Korbführung, links Rack guide, left Guides casiers, gauche	
04	01-294634-001	Rahmen, oben, kpl. Frame, above, assy Châssis, au dessus, cpl.	
05	00-886756-004	Isolierdurchführung Socket Douille	
06	01-294748-001	Dampfsperre Vapour baffle Barrière de vapeur	
07	00-324618-002	Federhalter, rechts Spring fastening, right Renforcement, droite	
08	00-324618-001	Federhalter, links Spring fastening, left Renforcement, gauche	
09	00-883838-001	Magnetschalter - Halterung Holding stripe - reed switch Tôle d'arrêt - contact magnétique	
10	01-240288-001	Magnetschalter Reed switch Contact magnétique	
11	01-246103-001	Federwinkel Spring mechanis Porte patin	
12	01-246110-001	Unterlegblech Disk Tôle entretoise	
13	01-510538-001	Bremsblech Brake plate Plaque de frein	
14	01-246104-001	Bremsbacke Brake block Patin de frein	
15	00-775866-002	Drucktransmitter Pressure transmitter Transmetteur de pression	
16	01-297533-001	Abdeckung Cover Couvercle	

Pos.-Nr. Key no. Réf.	Teile-Nr. Part no. No. pièce	Teile-Benennung Part name Nom de la pièce	Bemerkungen Remarks Remarques
17	01-510143-001	Schlauchklemme Hose clamp Collier de tuyau	
18	00-228715-002	Befestigungsschelle Clamp Collier	
19	00-324381-000	Feder Spring Ressort	
20	00-324402-008	Schlauch Hose Tuyau	
21	00-324402-018	Schlauch Hose Tuyau	
22	01-240372-001	Ersatzteilkit - Luftkammer Replacement kit - air trap Ens. De pièces détachées - cloche d'air	
23	00-276903-056	O-Ring O-ring Joint torrique	
24	00-775489-001	Stütze - Temperaturfühler Clamp - temperature probe Bride de fixation - sonde de tempéture	
25	00-775612-001	Temperaturfühler Temperature probe Sonde de température	
26	00-323949-001	Tankheizung Heating element Thermoplongeur	
27	00-067500-118	O-Ring O-ring Joint torrique	
28	00-898202-001	Tankflansch Drain body Corpe de vidange	
29	00-276903-028	O-Ring O-ring Joint torrique	
30	01-510527-001	Halterung - Ablaufpumpe Mounting bracket - drain pump Plaque de montage - pompe de vidange	
31	00-775854-003	Ablaufpumpe Drain pump Pompe de vidange	
32	00-226568-002	Kondensator Capacitor Condensateur	
33	00-226568-009	Kondensator Capacitor Condensateur	

Pos.-Nr. Key no. Réf.	Teile-Nr. Part no. No. pièce	Teile-Benennung Part name Nom de la pièce	Bemerkungen Remarks Remarques
34	00-867014-001	Abdeckung Cover Couvercle	
35	01-510552-001	Belüftungsventil Non return valve Clapet antiretour	
	01-510552-002	Belüftungsventil Non return valve Clapet antiretour	nur „R“ Modelle (Abwasser-Wärmerückgewinnung) only „R“ models (Drain - heat recovery) seulement „R“ modèles (Récupération - de chaleur vapeur)
36	00-775305-001	Dichtung Gasket Joint	
37	00-775531-001	Blindstopfen Plug Bouchon	
38	01-240159-001	Verbindungsstück Connection piece Raccord	
39	00-883961-002	Ablaufschlauch Drain hose Tuyau de vidange	
40	00-883181-002	T-Stück Tee Té	
41	01-294874-001	Schlauch Hose Tuyau	
42	01-294878-001	Schlauch Hose Tuyau	
43	01-510551-001	Schlauch Hose Tuyau	
44	00-898178-006	Schlauch Hose Tuyau	
45	01-294877-001	Schlauch Hose Tuyau	
46	00-165128-004	Kabelbinder Binder Collier	
47	00-323945-015	Schlauchklemme Hose clamp Collier de tuyau	
48	00-323945-037	Schlauchklemme Hose clamp Collier de tuyau	
49	00-323945-029	Schlauchklemme Hose clamp Collier de tuyau	

Pos.-Nr. Key no. Réf.	Teile-Nr. Part no. No. pièce	Teile-Benennung Part name Nom de la pièce	Bemerkungen Remarks Remarques
50	00-323945-033	Schlauchklemme Hose clamp Collier de tuyau	
51	00-695661-005	Kabelverschraubung Cable gland Presse-étoupe	
52	00-883676-001	Dosiernippel - Reiniger, kpl. Injector - detergent, assy Injecteur - détergent, cpl.	
53	01-240359-001	Aufkleber - Warnhinweis Adhesive label - warning Autocollant - avertissement	
54	00-325008-001	Verstellfuss Einschlagteil Food insert Insert de pied	
55	00-325007-001	Verstellfuss Einschraubteil Adjustable food Pied réglable	
56	00-775305-001	Dichtung Gasket Joint	
57	00-324097-000	Füllstück Fill piece Pièce de remplissage	
58	00-324183-000	Mutter Nut Ecrou	
59	00-886756-003	Isolierdurchführung Socket Douille	



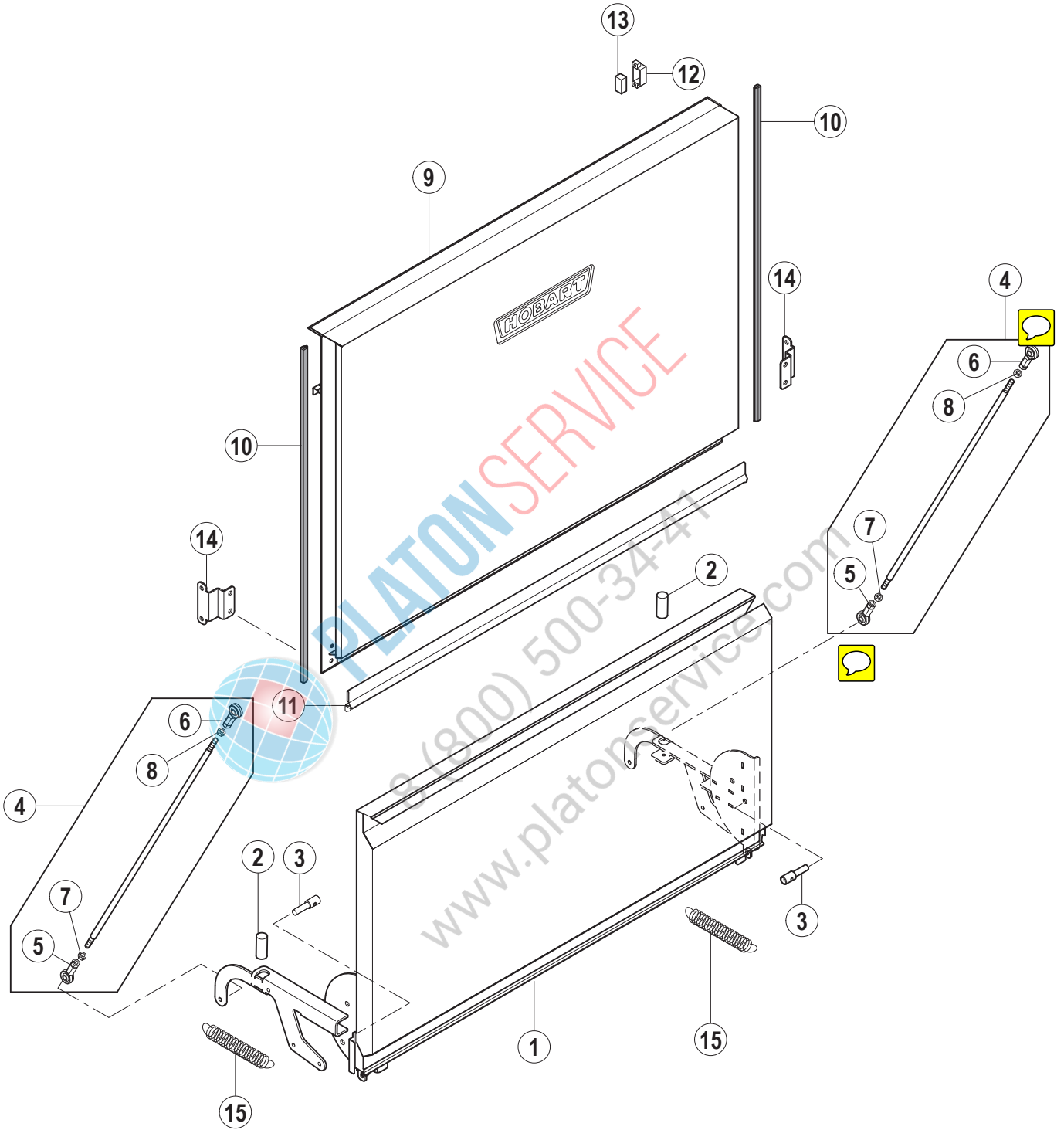

Pos.-Nr. Key no. Réf.	Teile-Nr. Part no. No. pièce	Teile-Benennung Part name Nom de la pièce	Bemerkungen Remarks Remarques
01	01-294672-002	Tür, kpl. Door, cpl. Porte, cpl.	
02	01-294682-001	Gummipuffer Buffer Patin	
03	01-294675-001	Achse Axle Axe	
04	01-510557-002	Hebegestänge, kpl. Bar Barre	(inkl. Teile-Nr. 5, 6, 7, 8) (incl. key no. 5, 6, 7, 8) (compr. ref. no. 5, 6, 7, 8)
05	01-510556-001	Gelenkkopf - Rechtsgewinde Joint head - Right hand thread Chape ariculée - Filet à droite	
06	01-510556-002	Gelenkkopf - Linksgewinde Joint head - Left hand thread Chape ariculée - Filet à gauche	
07	00-602491-000	Mutter - Rechtsgewinde Nut - Right hand thread Ecrou - Filet à droite	
08	00-605011-000	Mutter - Linksgewinde Nut - Left hand thread Ecrou - Filet à gauche	
09	01-294660-004	Schiebetür Sliding door Porte coulissant	
10	00-302207-028	Gleitschiene Sliding guide Glissière	
11	01-294665-002	Rinne Channel Guttière	
12	01-510648-001	Magnethalter Magnet support Support d'aimant	
13	00-775860-001	Türmagnet Door magnet Porte aimant	
14	01-294903-001	Winkel Bracket Attache	
15	01-246079-001	Feder Spring Ressort	

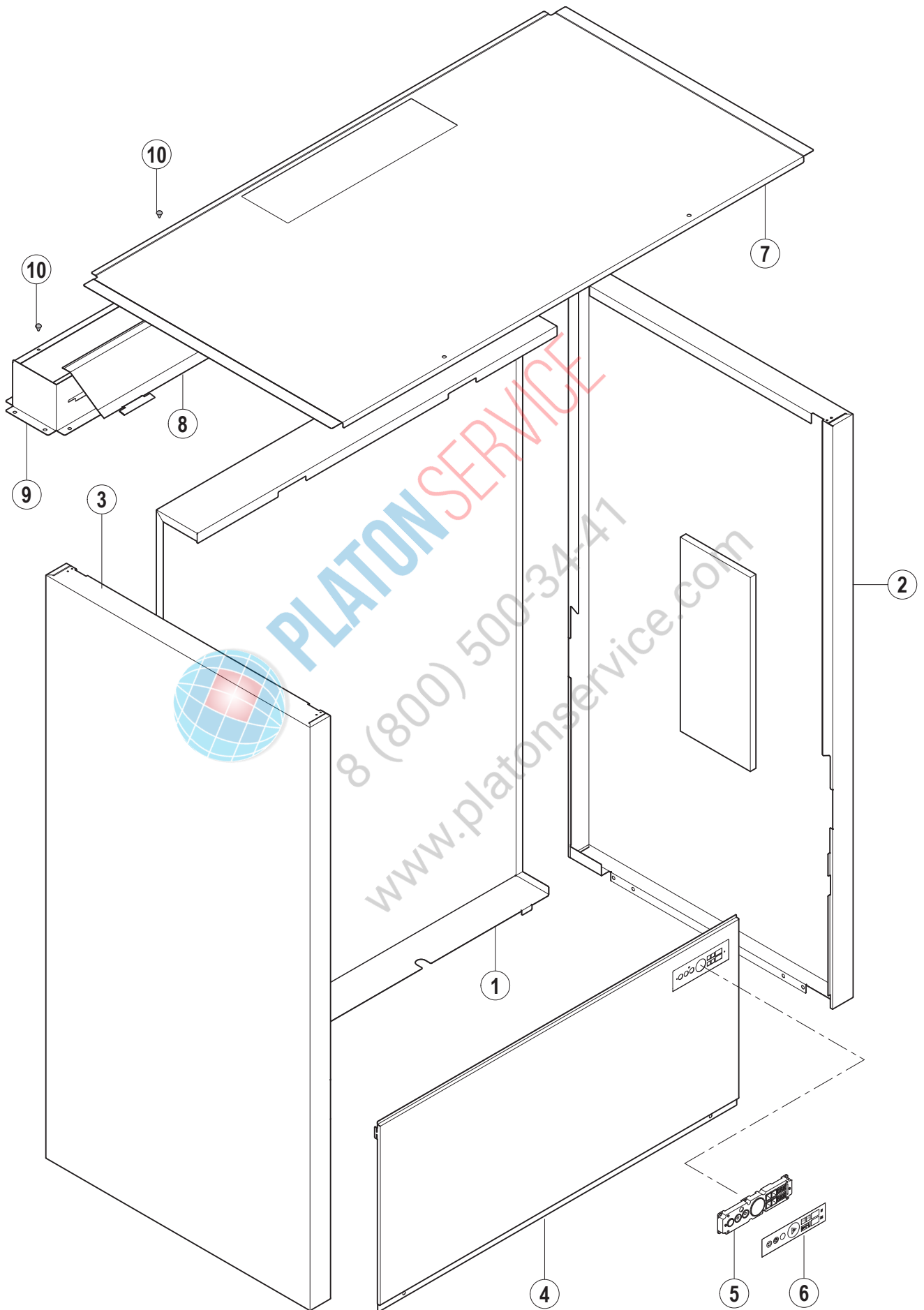

Pos.-Nr. Key no. Réf.	Teile-Nr. Part no. No. pièce	Teile-Benennung Part name Nom de la pièce	Bemerkungen Remarks Remarques
01	01-294776-002	Rückseitenverkleidung Rear side cover Couvercle de panneau arrière	
	01-294776-004	Rückseitenverkleidung Rear side cover Couvercle de panneau arrière	bei Abluft Wärmerückgewinnung / bis Serien-Nr. 8664 0400 with exhaust heat recovery / to Serial No. 8664 0400 avec air extrait récupération de chaleur vidange/ jusqu'au no. de série 8664 0400
02	01-510606-001	Seitenverkleidung, rechts Side panel, right Panneau latéral, droite	nur UXT only UXT seulement UXT
	01-510606-003	Seitenverkleidung, rechts Side panel, right Panneau latéral, droite	nur UPT only UPT seulement UPT
03	01-510606-002	Seitenverkleidung, links Side panel, left Panneau latéral, gauche	nur UXT only UXT seulement UXT
	01-510606-004	Seitenverkleidung, links Side panel, left Panneau latéral, gauche	nur UPT only UPT seulement UPT
04	01-294775-002	Frontverkleidung Front panel Panneau avant	
05	00-897540-001	Bedienteil UXT Operation unit Module de service	nur UXT nur UXT seulement UXT
	00-897540-002	Bedienteil UPT Operation unit Module de service	nur UPT only UPT seulement UPT
06	01-510518-001	Bedienfolie UXT Keyboard foil Plastron de commande	nur UXT only UXT seulement UXT
	01-510521-001	Bedienfolie UPT Keyboard foil Plastron de commande	nur UPT only UPT seulement UPT
07	01-294625-002	Verkleidung Deckel Panel Panneau	
08	01-294657-001	Klappe Flap Clapet	
09	01-510645-001	Belüftungskanal Ventilation duct Conduit de ventilation	
10	00-228828-001	Türstopper Door stopper Stopper la porte	

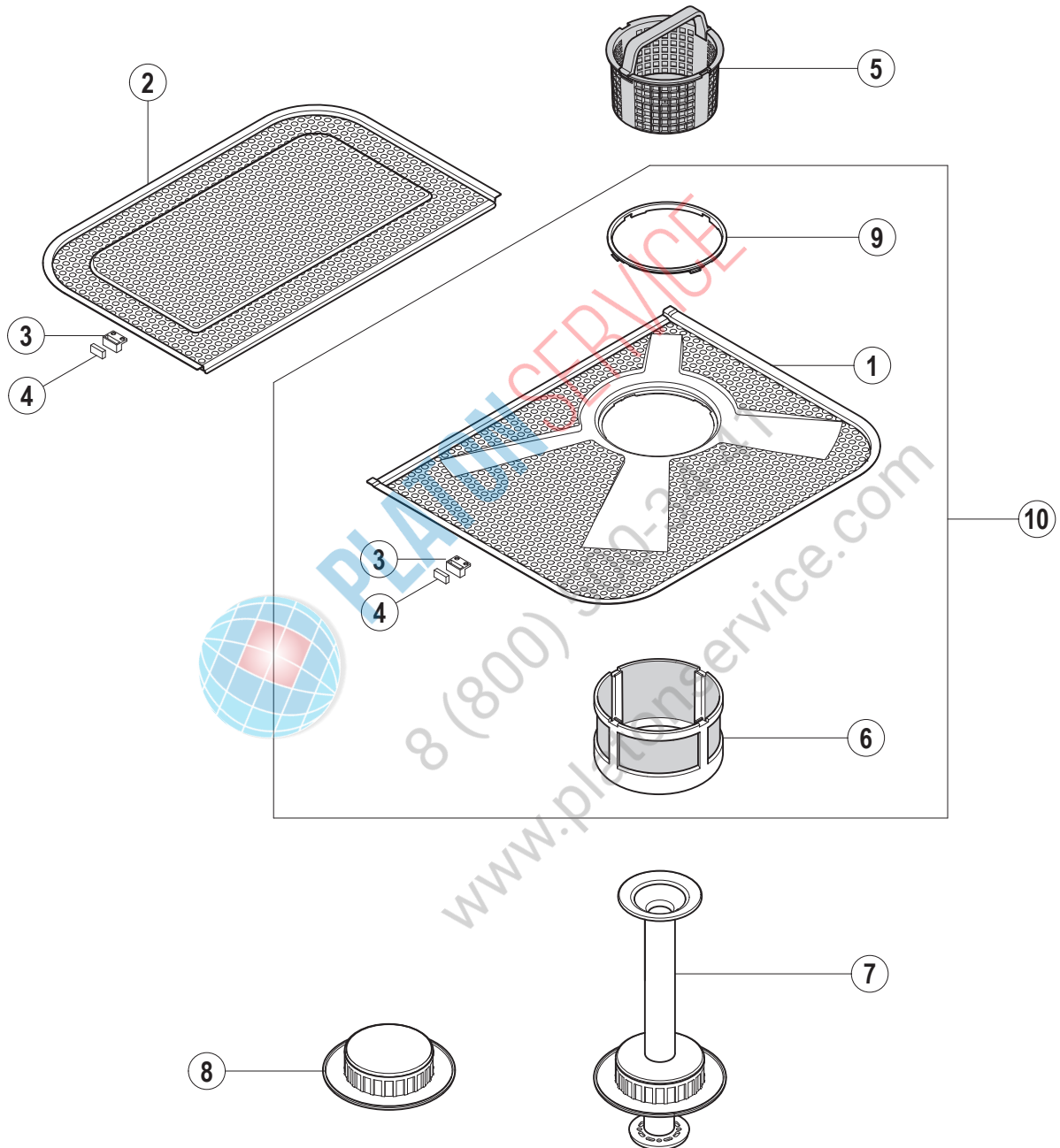

Pos.-Nr. Key no. Réf.	Teile-Nr. Part no. No. pièce	Teile-Benennung Part name Nom de la pièce	Bemerkungen Remarks Remarques
01	01-294741-001	Flachsieb, vorne Tank strainer Filtre	(inkl. Teile-Nr. 3, 4) (incl. key no. 3, 4) (compr. ref. no. 3, 4)
02	01-294742-001	Flachsieb, hinten Tank strainer Filtre	(inkl. Teile-Nr. 3, 4) (incl. key no. 3, 4) (compr. ref. no. 3, 4)
03	01-510648-001	Magnethalter Magnet support Support d'aimant	
04	00-775860-001	Magnet Magnet Aimant	
05	00-883584-001	Siebkorb, kpl. Strainer basket, assy Panier filtre, cpl.	
06	00-883582-001	Feinsieb, kpl. Fine strainer, assy Micro-filtre, cpl.	
07	00-883550-004	Standrohr, kpl. Overflow pipe, assy Tube trop-plein, cpl.	
08	00-883733-001	Ablaufsieb Drain strainer Filtre de vidange	
09	01-297809-001	Arretierung Locking ring Baque d'arrêt	
10	01-510694-001	Flachsieb, montiert Flat strainer Passoire plate	(inkl. Teil-Nr. 1, 3, 4, 6, 9) (incl. lten no. 1, 3, 4, 6, 9) (compr. ref. no. 1, 3, 4, 6, 9)

bis Serien-Nummer 8664 1620, ab Serien-Nummer 8664 1621 neues System - siehe Seite 20
to Serial-No. 8664 1620, from Serial-No. 8664 1621 new system - see page 20
d'ici no. de série 8664 1620, à partir du no. de série 8664 1621 nouvelle système - voir page 20

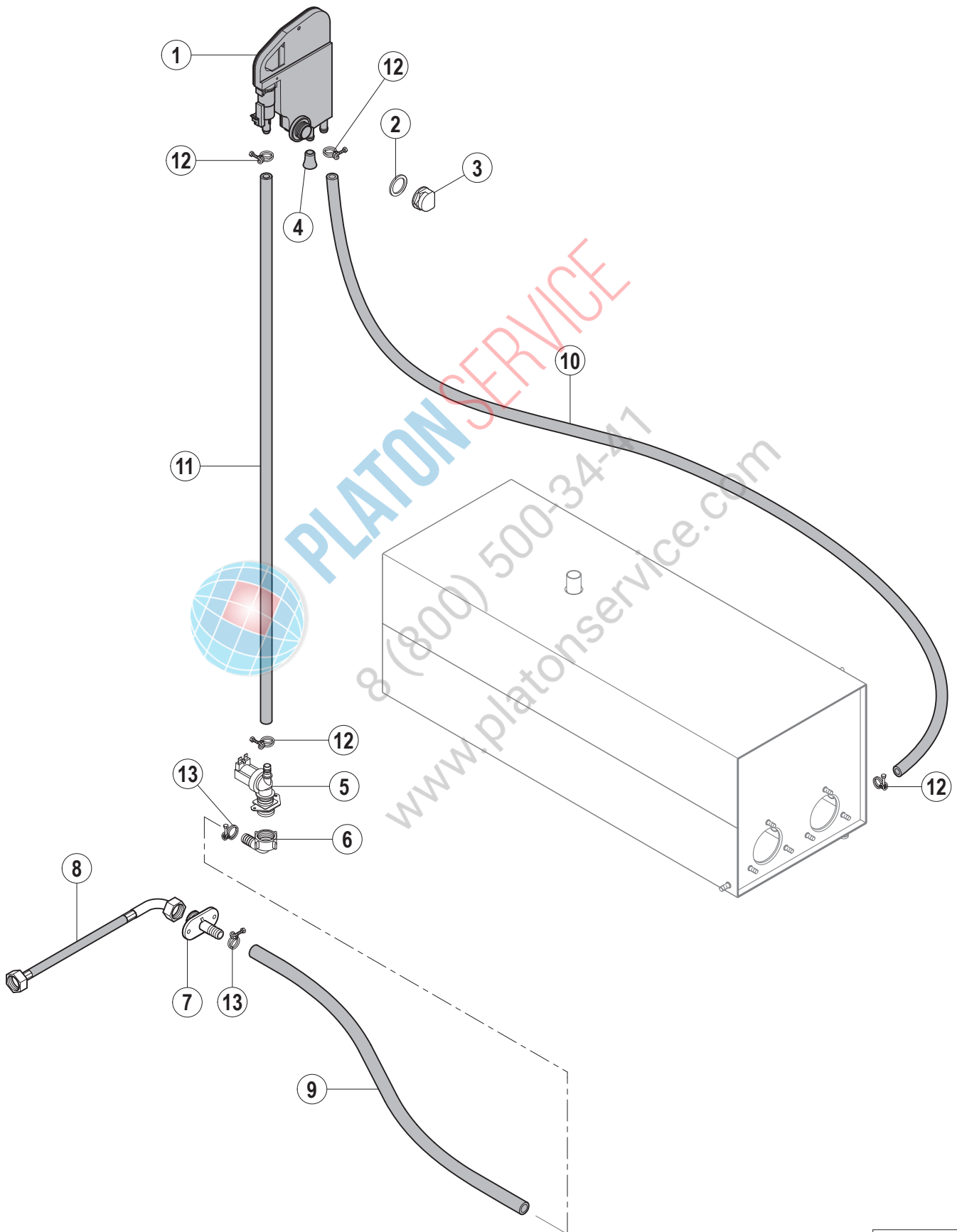

Pos.-Nr. Key no. Réf.	Teile-Nr. Part no. No. pièce	Teile-Benennung Part name Nom de la pièce	Bemerkungen Remarks Remarques
01	01-297510-002	Wassereinlauf Waterbreak Brise vide	
02	00-775305-001	Dichtung Gasket Joint	
03	00-324183-000	Mutter Nut Ecrou	
04	00-775531-001	Blindstopfen Blind plug Bouchon	
05	00-883658-001	Einlassventil Inlet valve Soupape d'admission	
06	01-510685-001	Winkelverschraubung Angle srew connection Coude	
07	01-294700-001	Füllschlauchanschluss Connection piece Raccord	
08	01-240316-001	Zulaufschlauch Fill hose Tuyau de vidange	
09	01-245571-013	Schlauch Hose Tuyau	
10	00-775559-032	Schlauch Hose Tuyau	
11	00-775559-029	Schlauch Hose Tuyau	
12	00-323945-018	Schlauchklemme Hose clamp Collier de tuyau	
13	00-323945-022	Schlauchklemme Hose clamp Collier de tuyau	

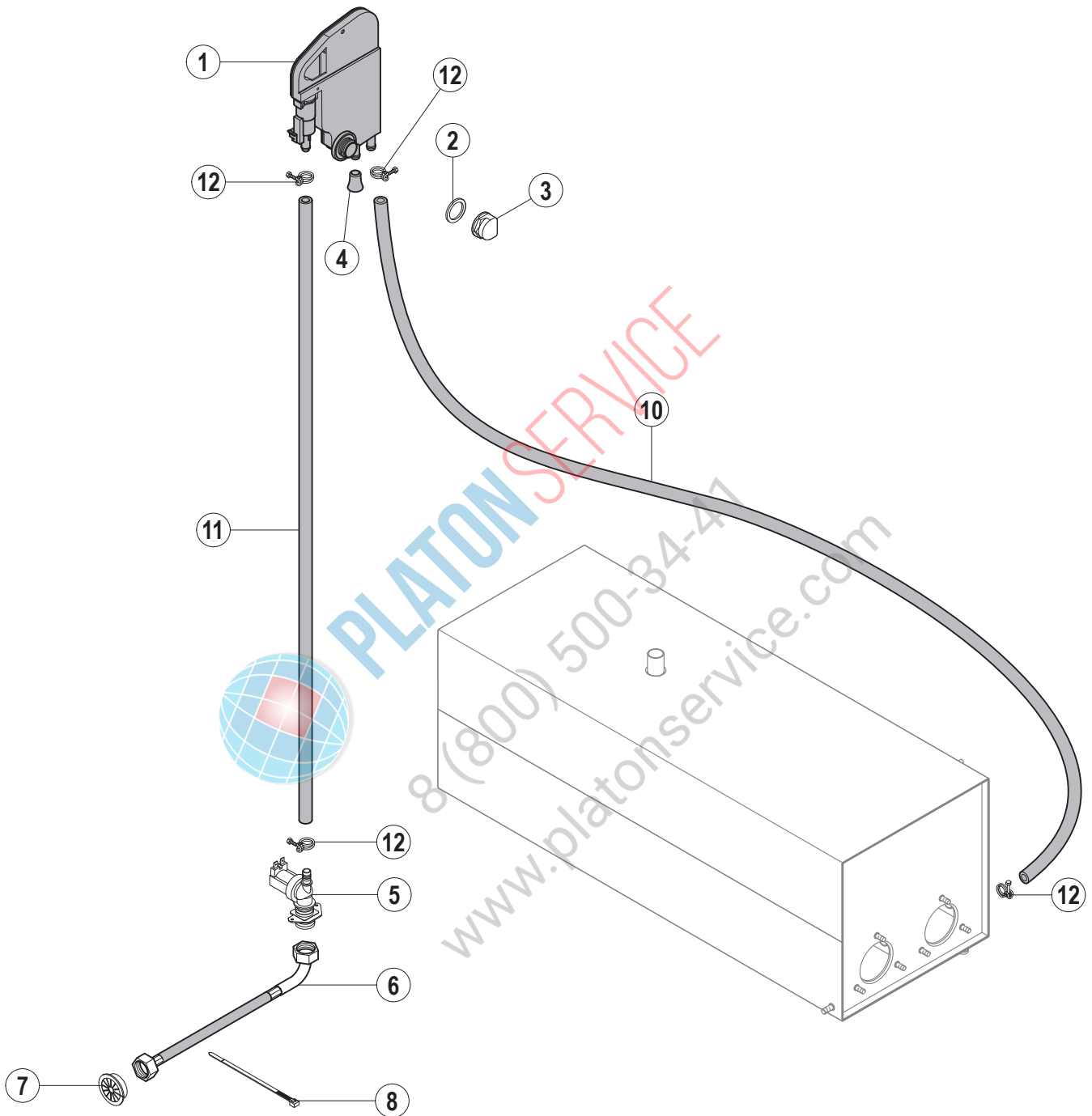

Pos.-Nr. Key no. Réf.	Teile-Nr. Part no. No. pièce	Teile-Benennung Part name Nom de la pièce	Bemerkungen Remarks Remarques
01	01-297510-002	Wassereinlauf Waterbreak Brise vide	
02	00-775305-001	Dichtung Gasket Joint	
03	00-324183-000	Mutter Nut Ecrou	
04	00-775531-001	Blindstopfen Blind plug Bouchon	
05	00-883658-001	Einlassventil Inlet valve Soupape d'admission	
06	01-240316-001	Zulaufschlauch Fill hose Tuyau de vidange	
07	01-510505-001	Kabeldurchführung, geschlitzt Cable duct Passe fil	
08	00-165128-003	Kabelbinder Binder Collier	
09	01-240316-003	Schlauch Hose Tuyau	
10	00-775559-032	Schlauch Hose Tuyau	
11	01-246371-006	Schlauch Hose Tuyau	
12	00-323945-018	Schlauchklemme Hose clamp Collier de tuyau	

bis Serien-Nummer 8664 1620, ab Serien-Nummer 8664 1621 neues System - siehe Seite 26
 to Serial-No. 8664 1620, from Serial-No. 8664 1621 new system - see page 26
 d'ici no. de série 8664 1620, à partir du no. de série 8664 1621 nouvelle système - voir page 26

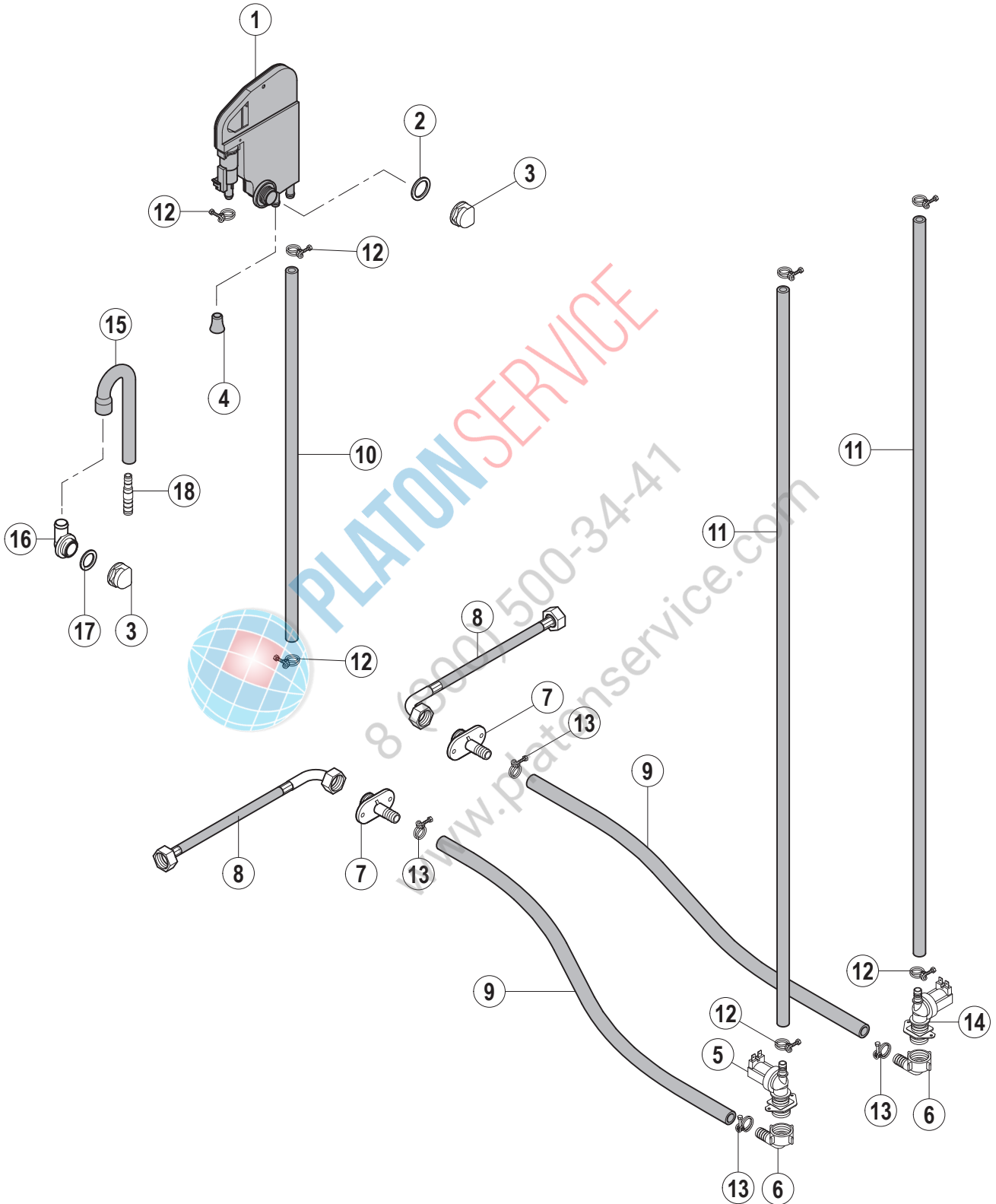

Pos.-Nr. Key no. Réf.	Teile-Nr. Part no. No. pièce	Teile-Benennung Part name Nom de la pièce	Bemerkungen Remarks Remarques
01	01-297510-002	Wassereinlauf Waterbreak Brise vide	
02	00-775305-001	Dichtung Gasket Joint	
03	00-324183-000	Mutter Nut Ecrou	
04	00-775531-001	Blindstopfen Blind plug Bouchon	
05	00-883658-001	Einlassventil Inlet valve Soupape d'admission	
06	01-510685-001	Winkelverschraubung Angle srew connection Coude	
07	01-294700-001	Füllschlauchanschluss Connection piece Raccord	
08	01-240316-001	Zulaufschlauch Fill hose Tuyau de vidange	
09	01-245571-013	Schlauch Hose Tuyau	
10	00-775559-029	Schlauch Hose Tuyau	
11	00-775559-030	Schlauch Hose Tuyau	
12	00-323945-018	Schlauchklemme Hose clamp Collier de tuyau	
13	00-323945-022	Schlauchklemme Hose clamp Collier de tuyau	
14	00-883658-002	Einlassventil Inlet valve Soupape d'admission	
15	00-883169-001	Schlauch Hose Tuyau	
16	00-324097-000	Füllstück Fill piece Pièce de remplissage	
17	00-172986-003	Dichtung Gasket Joint	

Pos.-Nr. Key no. Réf.	Teile-Nr. Part no. No. pièce	Teile-Benennung Part name Nom de la pièce	Bemerkungen Remarks Remarques
18	00-883256-003	Schlauchverbindsstück Connection piece Raccord	

**PLATON SERVICE**

8 (800) 500-34-47

www.platonservice.com



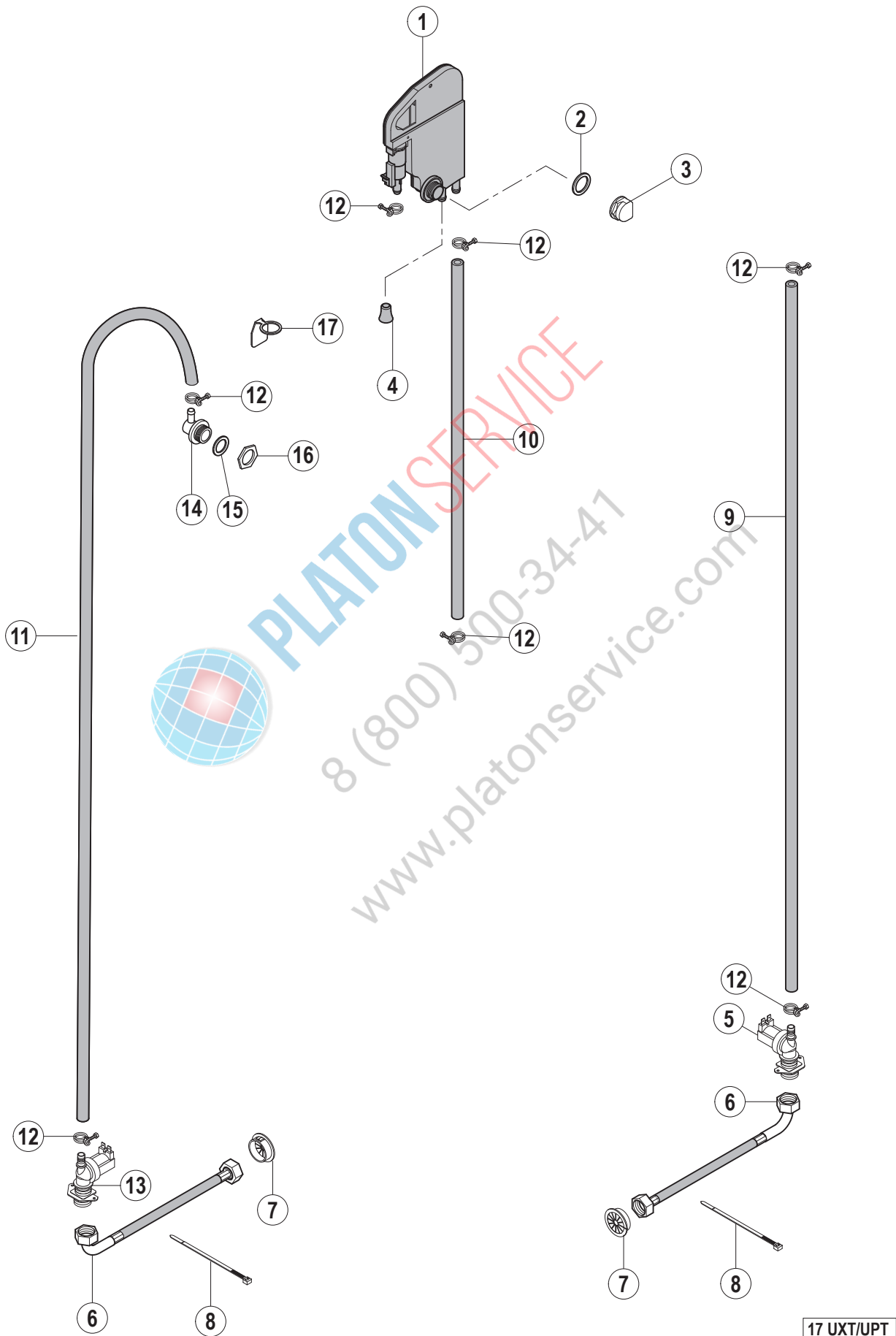

Pos.-Nr. Key no. Réf.	Teile-Nr. Part no. No. pièce	Teile-Benennung Part name Nom de la pièce	Bemerkungen Remarks Remarques
01	01-297510-002	Wassereinlauf Waterbreak Brise vide	
02	00-775305-001	Dichtung Gasket Joint	
03	00-324183-000	Mutter Nut Ecrou	
04	00-775531-001	Blindstopfen Blind plug Bouchon	
05	00-883658-001	Einlassventil Inlet valve Soupape d'admission	
06	01-240316-001	Zulaufschlauch Fill hose Tuyau de vidange	
07	01-510505-001	Kabeldurchführung, geschlitzt Cable duct Passe fil	
08	00-165128-003	Kabelbinder Binder Collier	
09	01-246372-010	Schlauch Hose Tuyau	
10	00-775559-029	Schlauch Hose Tuyau	
11	01-246371-006	Schlauch Hose Tuyau	
12	00-323945-018	Schlauchklemme Hose clamp Collier de tuyau	
13	00-883658-002	Einlassventil Inlet valve Soupape d'admission	
14	01-510704-001	Füllstück Fill piece Pièce de remplissage	nur UPT only UP/ seulement UPT
15	00-168611-002	Dichtung Gasket Joint	nur UPT only UPT seulement UPT
16	00-172739-014	Mutter Nut Ecrou	nur UPS only UPS seulement UPT
17	01-510710-001	Abdeckung Cover Couvercle	nur UPT only UPT seulement UPT

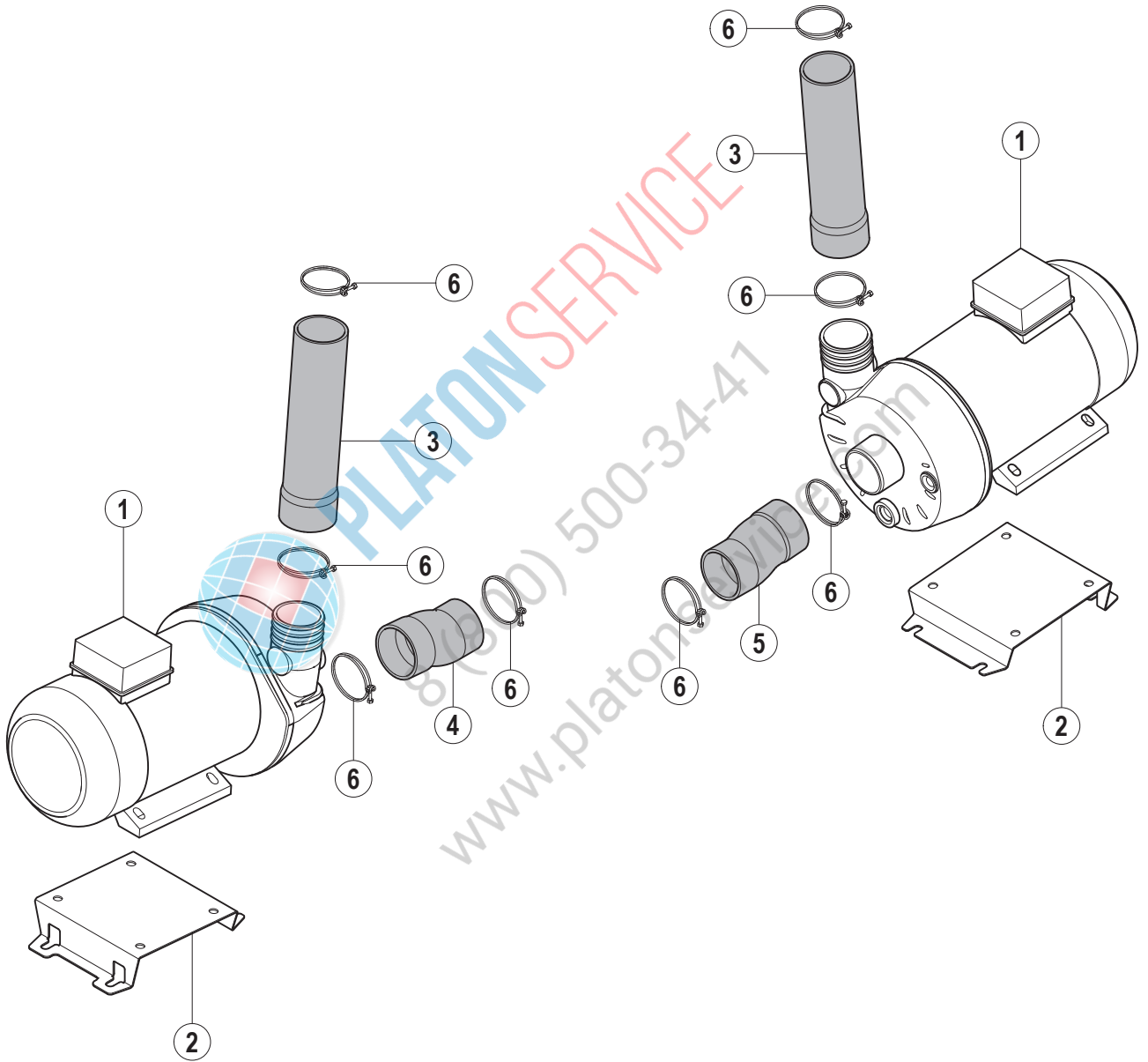

Pos.-Nr. Key no. Réf.	Teile-Nr. Part no. No. pièce	Teile-Benennung Part name Nom de la pièce	Bemerkungen Remarks Remarques
01	01-510510-001	Waschpumpe Wash pump Pompe de lavage	
	01-510632-001	Waschpumpe Wash pump Pompe de lavage	ab Serial-Nr. 8664 0252 from serial No. 8864 0252 onwards à partir du No. 8864 0252
01a	01-510510-010	Ersatzteilkit - Waschpumpe Replacement kit - wash pump Ens. de pièces détachées - pompe de lavage	50Hz 50Hz 50Hz
	01-510632-010	Ersatzteilkit - Waschpumpe Replacement kit - wash pump Ens. de pièces détachées - pompe de lavage	50Hz / ab Serial-Nr. 8664 0252 50Hz / from serial No. 8864 0252 onwards 50Hz / à partir du No. 8864 0252
02	01-510675-001	Halterung Mounting bracket Plaque de montage	
03	00-883141-004	Schlauch Hose Tuyau	
04	01-294885-001	Schlauch Hose Tuyau	
05	01-294950-001	Schlauch Hose Tuyau	
06	00-323945-076	Schlauchklemme Hose clamp Collier de tuyau	

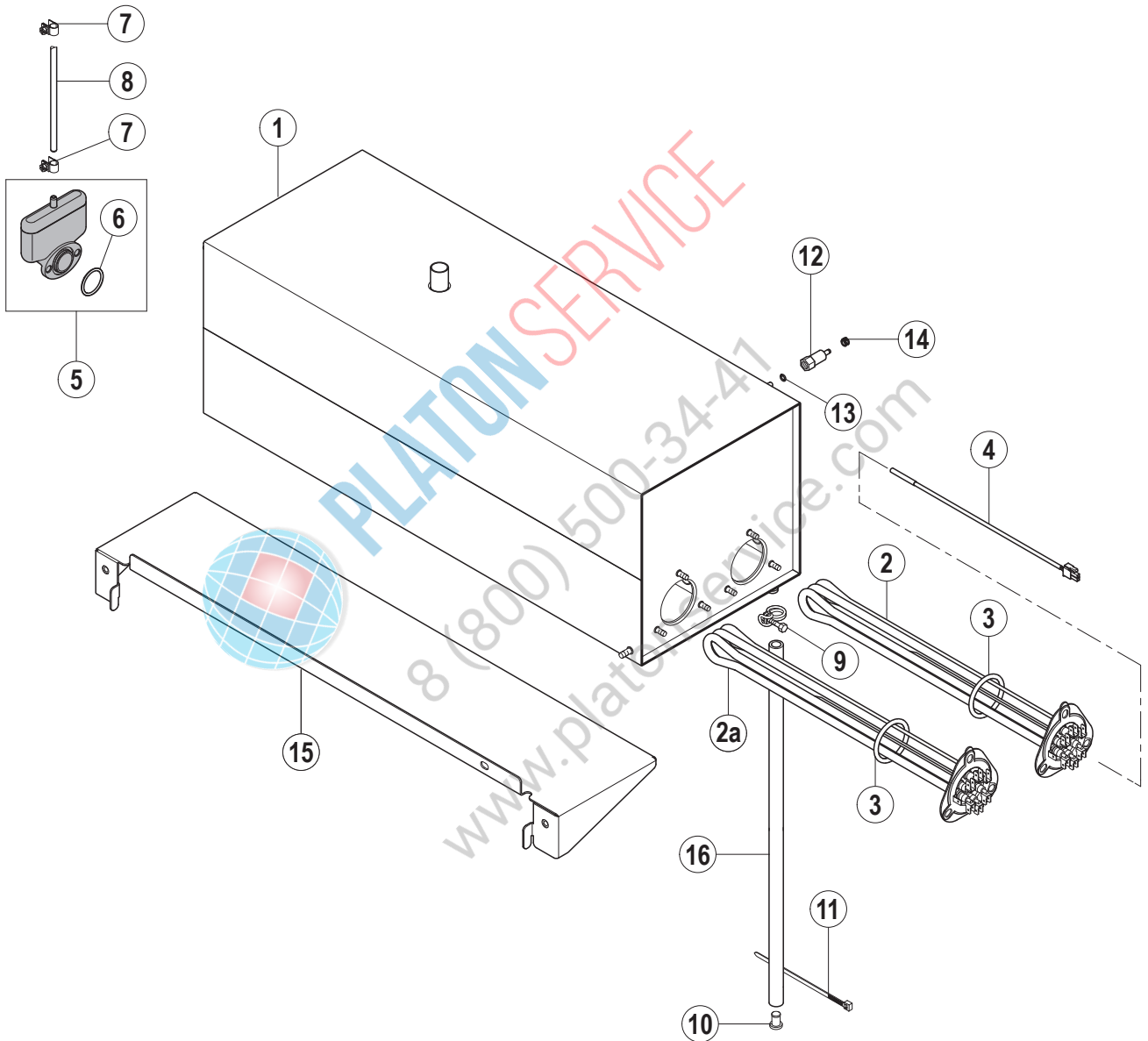

Pos.-Nr. Key no. Réf.	Teile-Nr. Part no. No. pièce	Teile-Benennung Part name Nom de la pièce	Bemerkungen Remarks Remarques
01	01-294795-001	Boiler, geschweisst Booster Chaudière	nur UXT only UXT seulement UXT
	01-294795-002	Boiler geschweisst Booster Chaudière	nur UPT only UPT seulement UPT
02	01-240135-003	Boilerheizung 9 kW Heating element - booster Thermoplngeur - chaudière	
2a	01-240135-002	Boilerheizung 6,15 kW Heating element - booster Thermoplngeur - chaudière	nur UXT only UXT seulement UXT
	01-240135-003	Boilerheizung 9 kW Heating element - booster Thermoplngeur - chaudière	nur UPT only UPT seulement UPT
03	01-240135-011	O-Ring O-ring Joint torrique	
04	00-775612-001	Temperaturfühler - Boiler Temperature probe - booster Sonde de température - chaudière	
05	01-240372-001	Ersatzteilkit - Luftkammer Replacement kit - air trap Ens. De pièces détachées - cloche d'air	
06	00-276903-056	O-Ring O-ring Joint torrique	
07	01-510143-001	Schlauchklemme Hose clamp Collier de tuyau	
08	00-324402-008	Schlauch Hose Tuyau	
09	00-323945-015	Schlauchklemme Hose clamp Collier de tuyau	
10	00-774512-001	Stopfen Plug Bouchon	
11	00-165128-001	Kabelbinder Binder Collier	
12	01-240452-001	Gewindenippel Threaded nipple Raccord fileté	
13	00-276903-055	O-Ring O-ring Joint torrique	
14	00-324510-073	Schlauchklemme Hose clamp Collier de tuyau	

Pos.-Nr. Key no. Réf.	Teile-Nr. Part no. No. pièce	Teile-Benennung Part name Nom de la pièce	Bemerkungen Remarks Remarques
15	01-294980-001	Boilerkonsole, kpl. Boiler console, assy Chaudière Console, cpl.	
16	00-774080-001	Schlauch Hose Tuyau	



PLATON SERVICE

8 (800) 500-34-47

www.platonservice.com



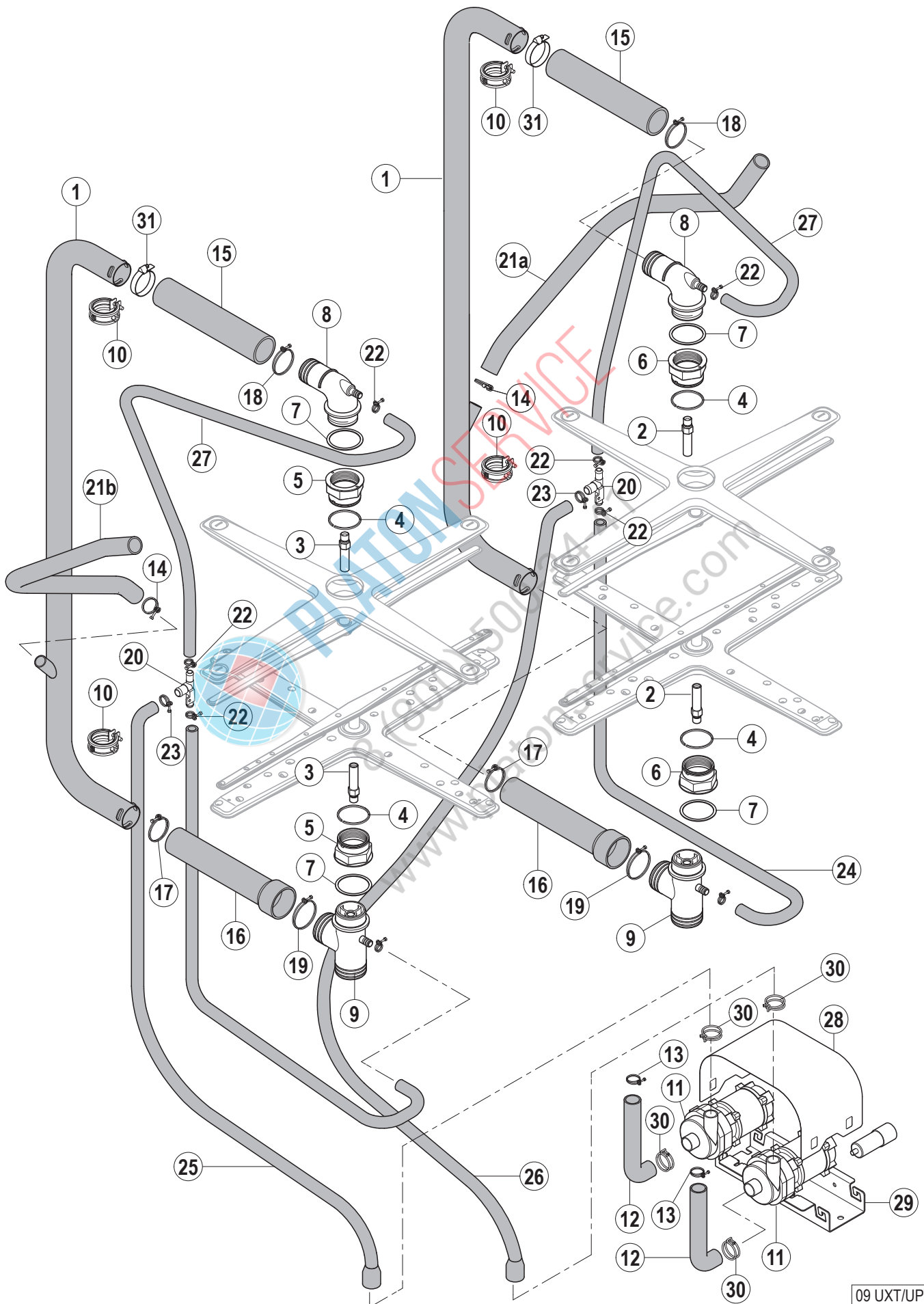

Pos.-Nr. Key no. Réf.	Teile-Nr. Part no. No. pièce	Teile-Benennung Part name Nom de la pièce	Bemerkungen Remarks Remarques
1	01-294827-001	Waschleitung, kpl. Manifold, assy Colonne, cpl.	nur UXT only UXT seulement UXT
	01-510558-003	Waschleitung, links, kpl. Manifold, left, assy Colonne, gauche, cpl.	nur UPT only UPT seulement UPT
	01-510558-004	Waschleitung, rechts, kpl. Manifold, right, assy Colonne, droite, cpl.	nur UPT only UPT seulement UPT
02	00-883500-001	Achse, rechts Axle, right Axe, droite	
03	00-883500-002	Achse, links Axle, left Axe, gauche	
04	00-324751-000	Dichtring Gasket Joint	
05	00-883497-001	Trennmutter, links Nut left Ecrou gauche	
06	00-883497-002	Trennmutter, rechts Nut right Ecrou droite	
07	00-172986-039	Dichtung Gasket Joint	
08	01-294619-001	Wascharmbasis, oben Upper wash arm hub Moyeu du bras de lavage supérieur	
09	01-294757-001	Wascharmbasis, unten Lower wash arm hub Moyeu du bras de lavage inférieur	
10	00-600785-000	Rohrschelle Pipe clamp Collier pour tuyau	
11	00-324093-021	Spülpumpe Rinse pump, assy Pompe de rinçage	
12	00-898242-006	Schlauch Hose Tuyau	
13	00-323945-035	Schlauchklemme Hose clamp Collier de tuyau	
14	00-323945-033	Schlauchklemme Hose clamp Collier de tuyau	nur UPT only UPT seulement UPT
15	00-883142-001	Schlauch Hose Tuyau	

Pos.-Nr. Key no. Réf.	Teile-Nr. Part no. No. pièce	Teile-Benennung Part name Nom de la pièce	Bemerkungen Remarks Remarques
16	01-294831-001	Schlauch Hose Tuyau	
17	00-323945-060	Schlauchklemme Hose clamp Collier de tuyau	
18	00-323945-064	Schlauchklemme Hose clamp Collier de tuyau	
19	00-323945-076	Schlauchklemme Hose clamp Collier de tuyau	
20	00-324071-000	T-Stück Tee Té	nur UXT only UXT seulement UXT
21a	00-883145-010	Schlauch Hose Tuyau	nur UPT only UPT seulement UPT
21b	00-883145-011	Schlauch Hose Tuyau	nur UPT only UPT seulement UPT
22	00-324510-202	Schlauchklemme Hose clamp Collier de tuyau	
23	00-324510-242	Schlauchklemme Hose clamp Collier de tuyau	nur UXT only UXT seulement UXT
24	01-510611-001	Schlauch Hose Tuyau	nur UXT only UXT seulement UXT
25	00-883167-001	Schlauch Hose Tuyau	nur UXT only UXT seulement UXT
26	00-883167-005	Schlauch Hose Tuyau	nur UXT only UXT seulement UXT
27	01-240170-008	Schlauch Hose Tuyau	nur UXT only UXT seulement UXT
28	01-510612-001	Abdeckung Cover Couvercle	
29	01-510610-001	Halterung Mounting bracket Plaque de montage	
30	00-324510-327	Schlauchklemme Hose clamp Collier de tuyau	
31	00-166513-003	Schlauchklemme Hose clamp Collier de tuyau	



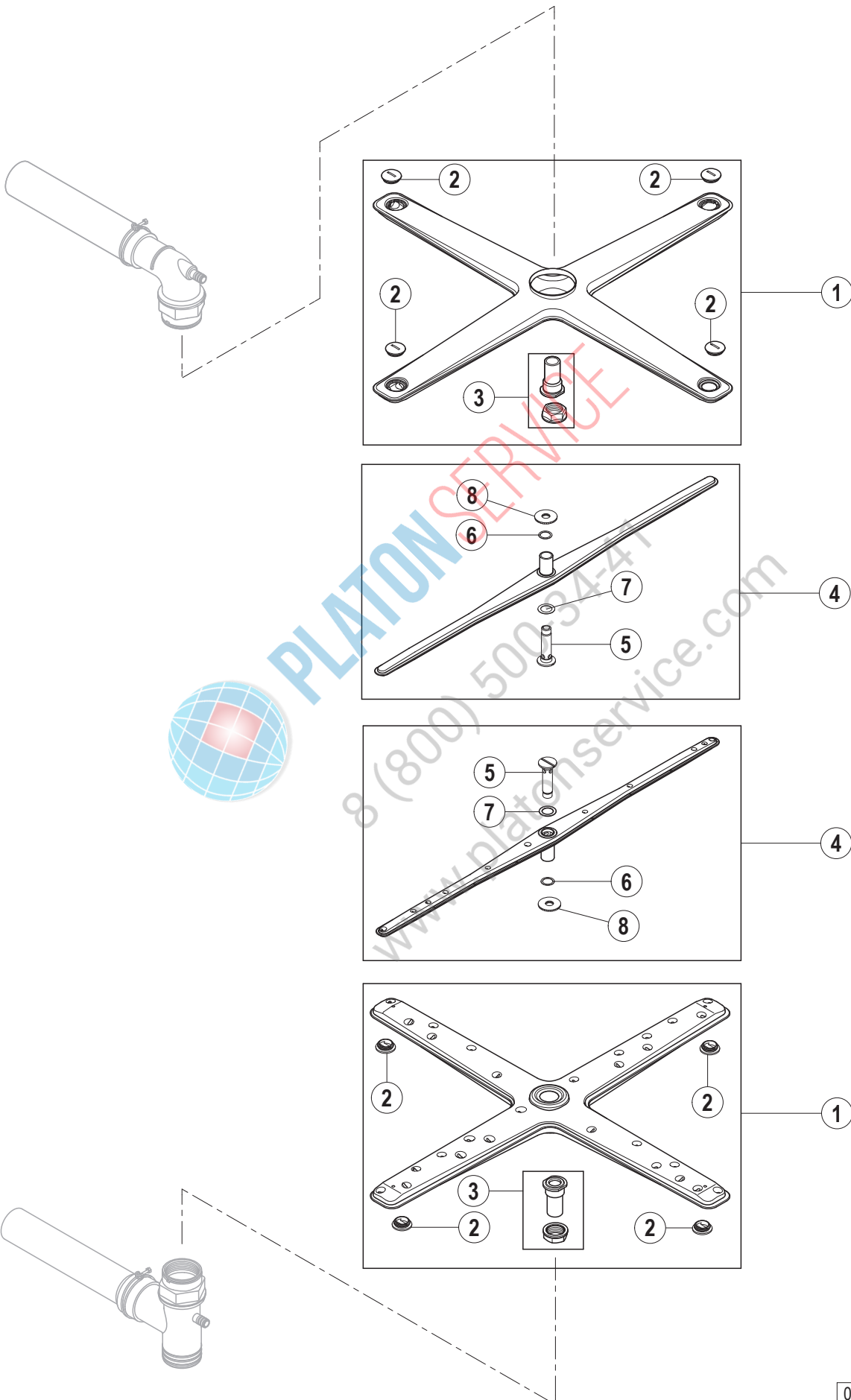

Pos.-Nr. Key no. Réf.	Teile-Nr. Part no. No. pièce	Teile-Benennung Part name Nom de la pièce	Bemerkungen Remarks Remarques
01	01-294687-001	Wascharm, kpl. Washarm, assy Bras de lavage, cpl.	(inkl. Teile-Nr. 2, 3) (incl. key no. 2, 3) (compr. ref. no. 2, 3)
02	00-324785-000	Stopfen Plug Bouchon	4 Stück 4 Pieces 4 Pièces
03	01-510702-001	Ersatzteilkit - Führung Replacement kit - Guide Ens. De pièces détachées - Guidage	
04	01-294641-001	Spülarm, kpl. Rinse arm, assy Bras de rincage, cpl.	(inkl. Teile-Nr. 5 ,6, 7, 8) (incl. key no. 5 ,6, 7, 8) (compr. ref. no. 5 ,6, 7, 8)
05	01-294879-001	Achse - Spülarm Axle - rinse arm Axe - bras de rincage	
06	00-774072-001	Teflonscheibe Teflon washer Rondelle de Téflon	
07	00-774072-002	Teflonscheibe Teflon washer Rondelle de Téflon	
08	01-240205-001	Rändelmutter Milled nut Ecrou moleté	



PLATON SERVICE
8 (800) 500-34-47
www.platonservice.com

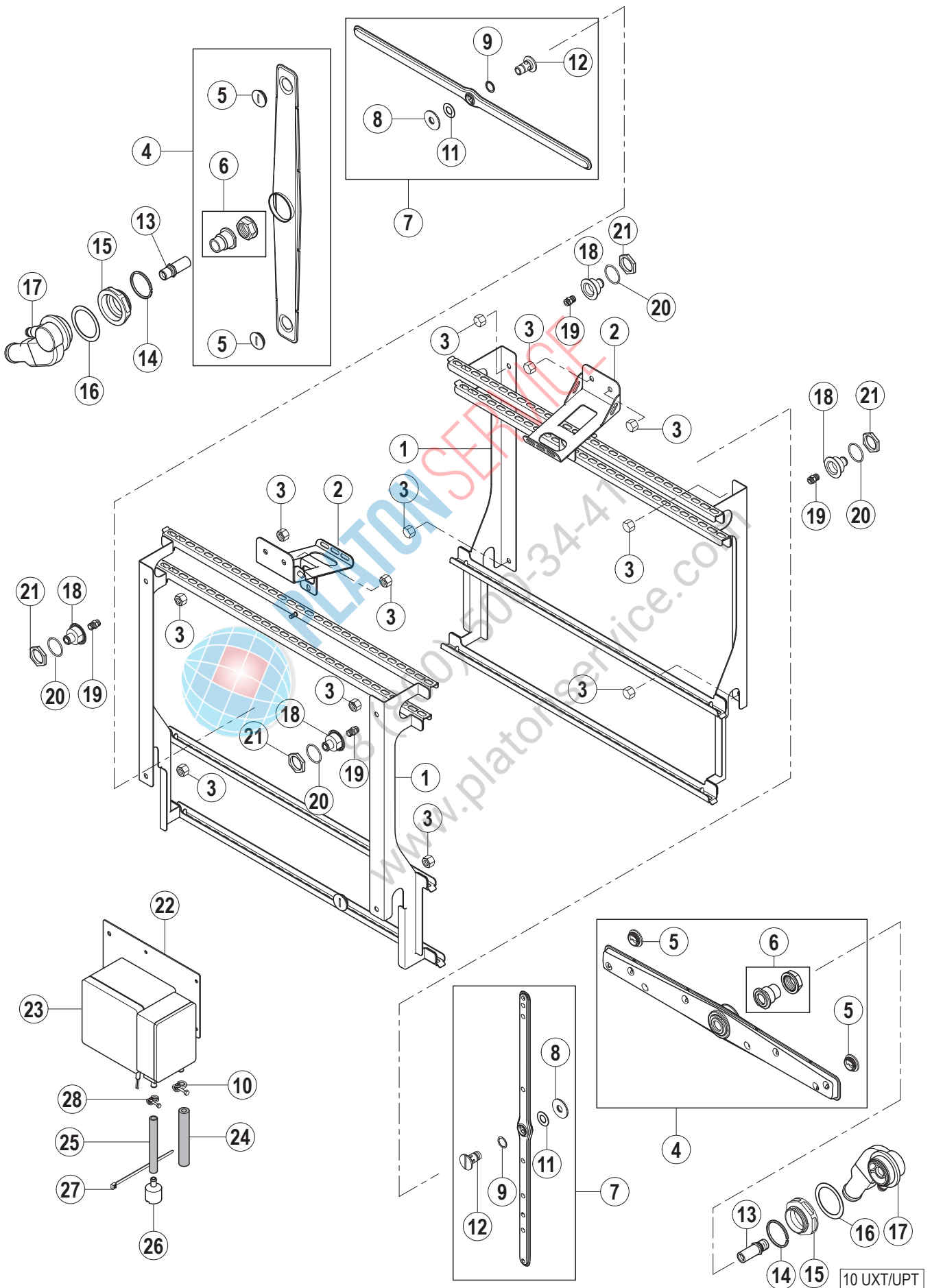

Pos.-Nr. Key no. Réf.	Teile-Nr. Part no. No. pièce	Teile-Benennung Part name Nom de la pièce	Bemerkungen Remarks Remarques
01	01-510531-001	Seitenführungen GN Lateral guide Guidage de coté	
02	01-510591-001	Haltewinkel EN Box Mounting bracket Plaque de montage	
03	00-602513-000	Hutmutter Nut Ecrou	
04	01-294667-001	Wascharm, kpl. Wash arm, assy Bras de lavage, cpl.	(inkl. Teile-Nr. 5, 6) (incl. key no. 5, 6) (compr. ref. no. 5, 6)
05	00-886610-000	Stopfen Plug Bouchon	4 Stück 4 pieces 4 pièces
06	00-883974-003	Ersatzteilkit - Führung Replacement kit - Guide Ens. de pièces détachées - Guidage	
07	01-240096-005	Spülarm, kpl. Rinse arm, assy Bras de rinçage, cpl.	(inkl. Teile-Nr. 8, 9, 10, 11, 12) (incl. key no. 8, 9, 10, 11, 12) (compr. ref. no. 8, 9, 10, 11, 12)
08	01-240205-001	Rändelmutter Milled nut Ecrou moleté	
09	00-774072-001	Teflonscheibe Teflon washer Rondelle du Téflon	
10	00-323945-015	Schlauchklemme Hose clamp Collier de tuyau	
11	00-774072-007	Teflonscheibe Teflon washer Rondelle du Téflon	
12	01-510699-001	Achse - Spülarm Axle - rinse arm Axe - bras de rinçage	
13	01-294669-001	Achse Axle Axe	
14	00-775933-003	Dichtring Gasket Joint	
15	01-240021-001	Trennmutter Nut Ecrou	
16	00-172986-019	Dichtung Gasket Joint	
17	01-294038-001	Wascharmlagerung Wash arm mounting Bras de lavage stockage	

Pos.-Nr. Key no. Réf.	Teile-Nr. Part no. No. pièce	Teile-Benennung Part name Nom de la pièce	Bemerkungen Remarks Remarques
18	01-510541-002	Halterung Düsen Bracket jet Support jet	
19	01-510545-001	Vollkegeldüse Nozzle Buse conique	
20	00-276903-060	O-Ring O-ring Joint torrique	
21	00-172739-002	Mutter Nut Ecrou	
22	01-294798-001	Halter - Dosierpumpe Mounting bracket - dosing pump Plaque de montage - pompe de dosage	
23	01-297059-002	Dosierpumpe Dosing pump Pompe de dosage	
23a	00-785539-073	Sicherung T2A Fuse T2A Fusible T2A	
24	01-510605-003	Schlauch Hose Tuyau	
25	01-510595-002	Schlauch Hose Tuyau	
26	01-510594-001	Ansaugstück Suction piece Pièce d'aspiration	
27	00-165128-001	Kabelbinder Binder Collier	
28	00-323945-012	Schlauchklemme Hose clamp Collier de tuyau	
29	00-323945-015	Schlauchklemme Hose clamp Collier de tuyau	



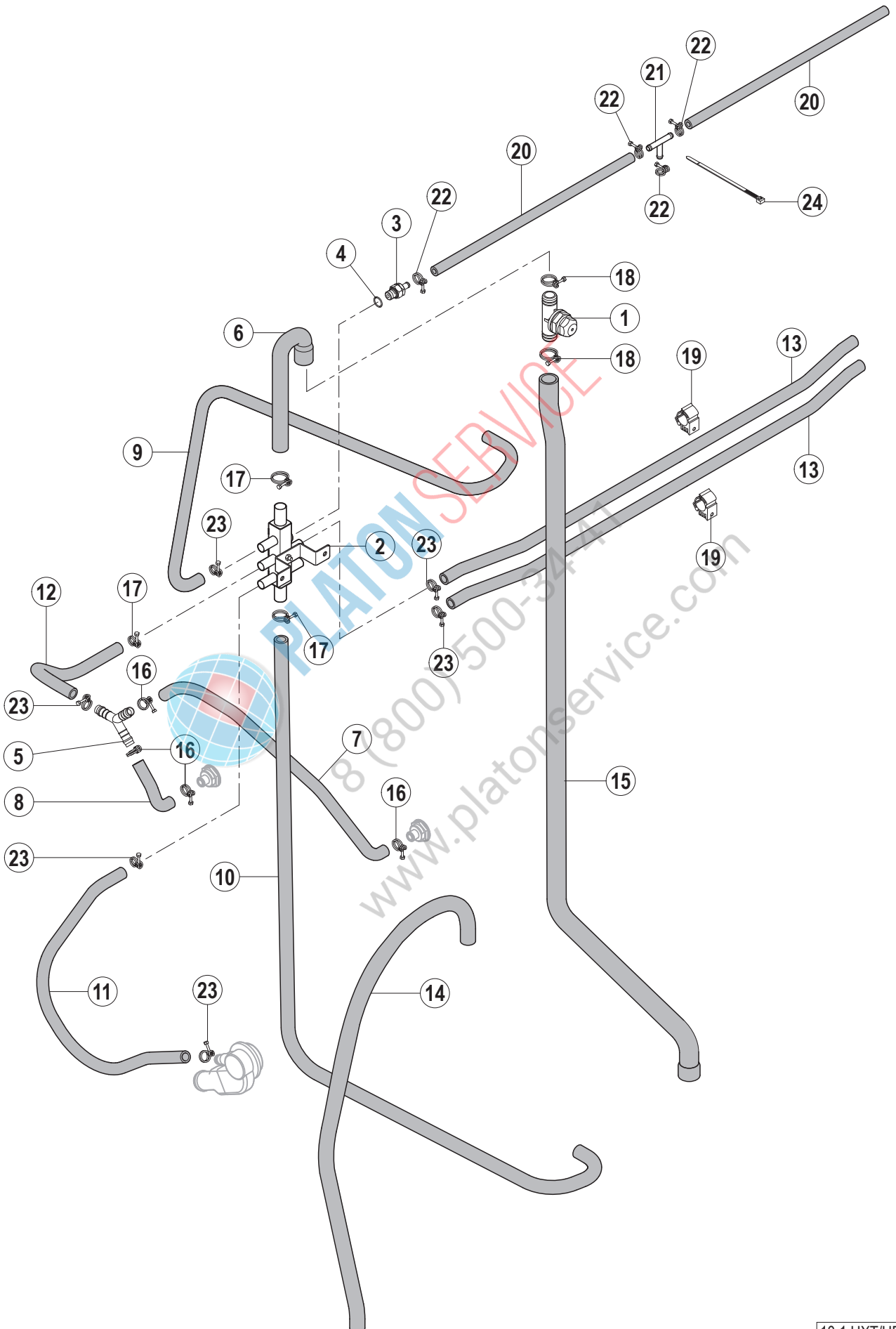

Pos.-Nr. Key no. Réf.	Teile-Nr. Part no. No. pièce	Teile-Benennung Part name Nom de la pièce	Bemerkungen Remarks Remarques
01	00-886606-000	Belüftungsventil Ventilation valve Vanne de ventilation	
02	01-510578-001	Verteiler, rechts Distributeur, right Distributeur, droite	
03	01-510559-001	Rückschlagventil Non return valve Soupape de non retour	
04	00-276903-052	O-Ring O-ring Joint torrique	
05	00-174047-001	Y-Stück Y-piece Y-pièce	
06	01-510576-001	Schlauch Hose Tuyau	
07	00-898247-016	Schlauch Hose Tuyau	
08	00-898247-006	Schlauch Hose Tuyau	
09	01-240170-008	Schlauch Hose Tuyau	
10	01-294870-001	Schlauch Hose Tuyau	
11	01-240170-007	Schlauch Hose Tuyau	
12	01-240170-002	Schlauch Hose Tuyau	
13	01-240170-003	Schlauch Hose Tuyau	
14	01-510643-001	Schlauch Hose Tuyau	
15	01-510503-001	Schlauch Hose Tuyau	
16	00-323945-018	Schlauchklemme Hose clamp Collier de tuyau	
17	00-323945-025	Schlauchklemme Hose clamp Collier de tuyau	

Pos.-Nr. Key no. Réf.	Teile-Nr. Part no. No. pièce	Teile-Benennung Part name Nom de la pièce	Bemerkungen Remarks Remarques
18	00-323945-029	Schlauchklemme Hose clamp Collier de tuyau	
19	00-884375-001	Wellenschlauchclip Clip Agrafe	
20	01-510605-002	Schlauch Hose Tuyau	
21	01-510602-001	T-Stück Tee Té	
22	00-323945-015	Schlauchklemme Hose clamp Collier de tuyau	
23	00-323945-021	Schlauchklemme Hose clamp Collier de tuyau	
24	00-165128-001	Kabelbinder Binder Collier	
 PLATON SERVICE 8 (800) 500-34-41 www.platonservice.com			



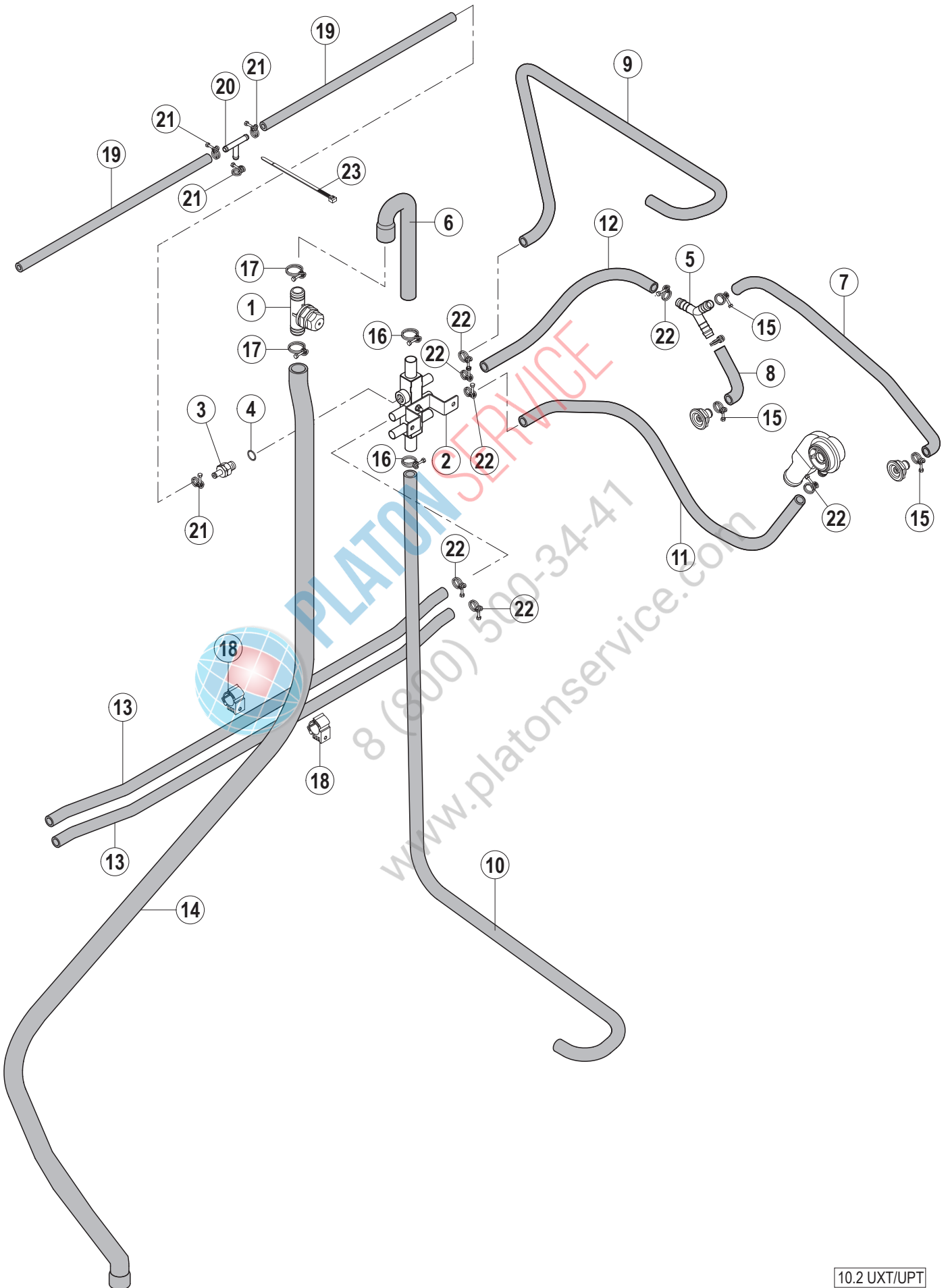

Pos.-Nr. Key no. Réf.	Teile-Nr. Part no. No. pièce	Teile-Benennung Part name Nom de la pièce	Bemerkungen Remarks Remarques
01	00-886606-000	Belüftungsventil Ventilation valve Vanne de ventilation	
02	01-510578-002	Verteiler, links Distributeur, left Distributeur, gauche	
03	01-510559-001	Rückschlagventil Non return valve Soupape de non retour	
04	00-276903-052	O-Ring O-ring Joint torrique	
05	00-174047-001	Y-Stück Y-piece Y-pièce	
06	01-510576-001	Schlauch Hose Tuyau	
07	00-898247-016	Schlauch Hose Tuyau	
08	00-898247-006	Schlauch Hose Tuyau	
09	01-240170-008	Schlauch Hose Tuyau	
10	01-294870-001	Schlauch Hose Tuyau	
11	01-240170-007	Schlauch Hose Tuyau	
12	01-240170-002	Schlauch Hose Tuyau	
13	01-240170-003	Schlauch Hose Tuyau	
14	01-294871-001	Schlauch Hose Tuyau	
15	00-323945-018	Schlauchklemme Hose clamp Collier de tuyau	
16	00-323945-025	Schlauchklemme Hose clamp Collier de tuyau	
17	00-323945-029	Schlauchklemme Hose clamp Collier de tuyau	

Pos.-Nr. Key no. Réf.	Teile-Nr. Part no. No. pièce	Teile-Benennung Part name Nom de la pièce	Bemerkungen Remarks Remarques
18	00-884375-001	Wellenschlauchclip Clip Agrafe	
19	01-510605-002	Schlauch Hose Tuya	
20	01-510602-001	T-Stück Tee Té	
21	00-323945-015	Schlauchklemme Hose clamp Collier de tuyau	
22	00-323945-021	Schlauchklemme Hose clamp Collier de tuyau	
23	00-165128-001	Kabelbinder Binder Collier	



PLATON SERVICE

8 (800) 500-34-41

www.platonservice.com



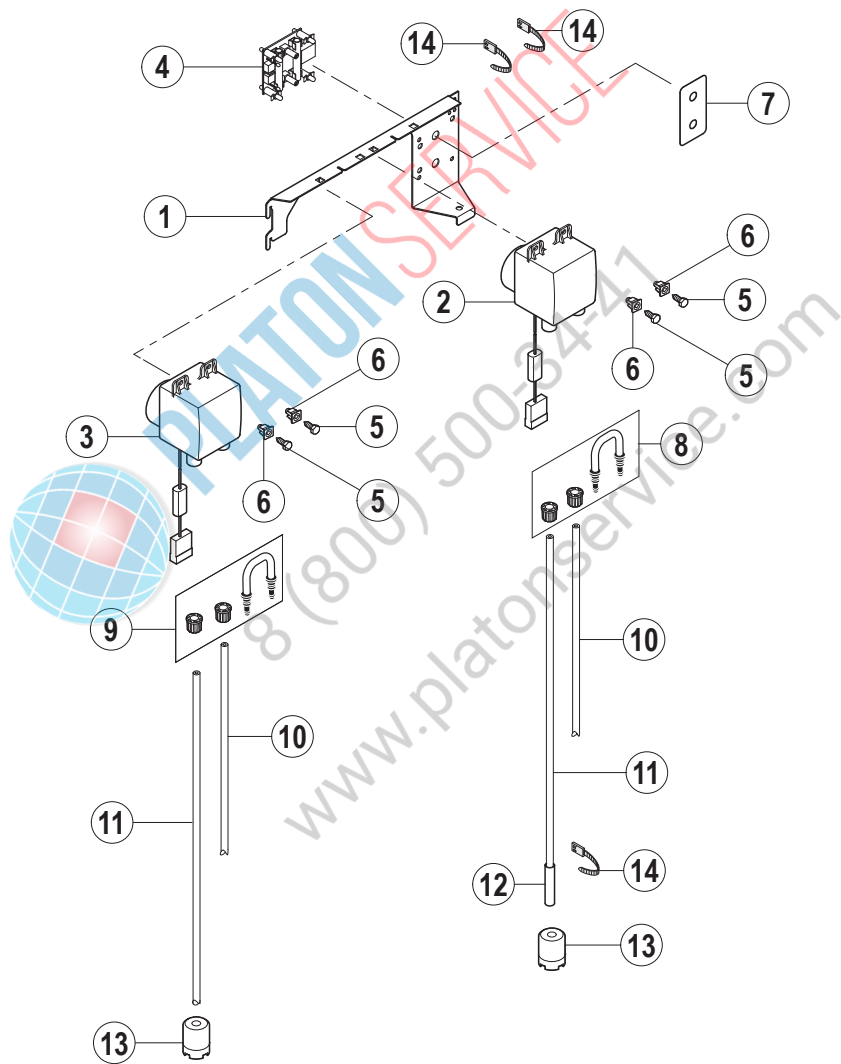

Pos.-Nr. Key no. Réf.	Teile-Nr. Part no. No. pièce	Teile-Benennung Part name Nom de la pièce	Bemerkungen Remarks Remarques
01	01-294920-001	Halterung - Dosierpumpen Mounting bracket - dosing pumps Plaque de monatge - pompes de dosage	
02	00-883860-001	Dosierpumpe - Klarspüler Dosing pump - rinse aid Pompe de dosage - prodiut de rinçage	
03	00-883860-002	Dosierpumpe - Reiniger Dosing pump - detergent Pompe de dosage - détergent	
04	00-883930-001	Chemiesensor Chemicals deficiency sensor Captuers manque de dosage	
05	00-609834-000	Blechschraube Sechskant Screw hex Vis hex	
06	00-775460-001	Einsteckmutter Clip nut Ecrou de clip	
07	00-883896-001	Aufkleber - Chemiesensor Adhesive label - hemicals sensor Autocollant - capteurs de dosage	
08	00-883860-011	Ersatzteilkit - Klarspüler Replacement kit - rinse aid Ens. de pièces détachées - prodiut de rinçage	
09	00-883860-012	Ersatzteilkit - Reiniger Replacement kit - detergent Ens. de pièces détachées - detergent	
10	01-246301-016	Druckschlauch Pressure hose Tuyau de pression	
11	01-246301-011	Saugschlauch Suction hose Tuyau d'aspiration	
12	01-246210-001	PE Schlauch (blau) Hose (blue) Tuyau (bleu)	
13	00-775239-001	Ansaugstück Suction piece Pièce d'aspiration	
14	00-165128-001	Kabelbinder Binder Collier	

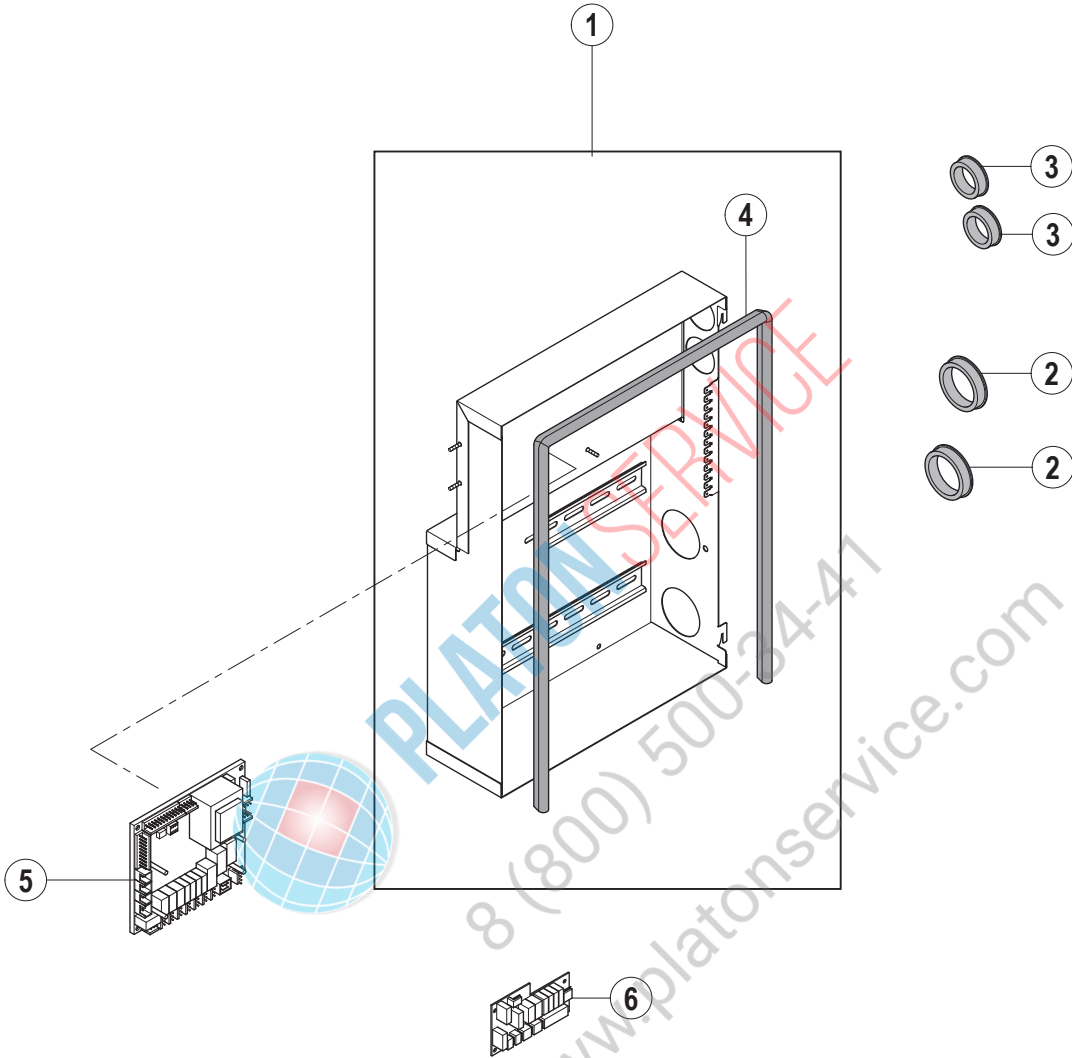

Pos.-Nr. Key no. Réf.	Teile-Nr. Part no. No. pièce	Teile-Benennung Part name Nom de la pièce	Bemerkungen Remarks Remarques
01	00-883506-003	Schaltkasten mit Dichtung Control box with Gasket Coffret électrique avec joint	
02	00-886756-001	Kabeldurchführung Cable duct Passe fil	
03	00-886756-003	Kabeldurchführung Cable duct Passe fil	
04	00-229169-012	Dichtung Gasket Joint	
05	00-897545-001	Steuerung - vollbestückt Control unit - fully equipped Unité de commande - équipée complètement	
06	00-897546-002	Erweiterungskarte Extension board Unité d'extension	



PLATON SERVICE

8 (800) 500-34-47

www.platonservice.com

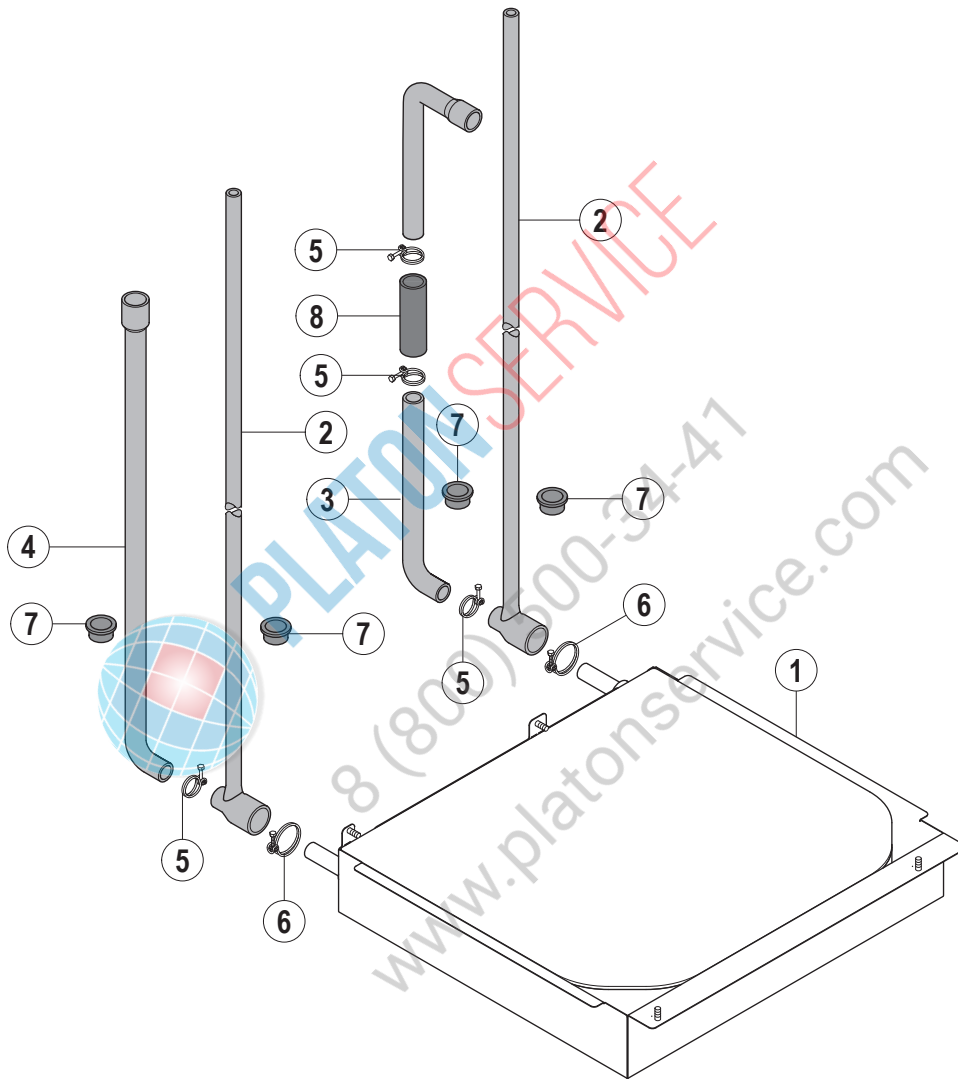

Pos.-Nr. Key no. Réf.	Teile-Nr. Part no. No. pièce	Teile-Benennung Part name Nom de la pièce	Bemerkungen Remarks Remarques
01	00-883638-002	Wärmetauscher Heat exchanger Échangeur thermique	
02	00-883747-002	T-Stück Wärmetauscher Tee heat exchanger Té de échangeur thermique	
03	00-883170-003	Schlauch Hose Tuyau	
04	00-883840-001	Schlauch Hose Tuyau	
05	00-323945-025	Schlauchklemme Hose clamp Collier de tuyau	
06	00-323945-035	Schlauchklemme Hose clamp Collier de tuyau	
07	00-886756-002	Isolierungsdurchführung Cable duct Passe fil	
08	00-228629-032	Rohr Pipe Tube	



PLATON SERVICE
8 (800) 500-34-47
www.platonservice.com

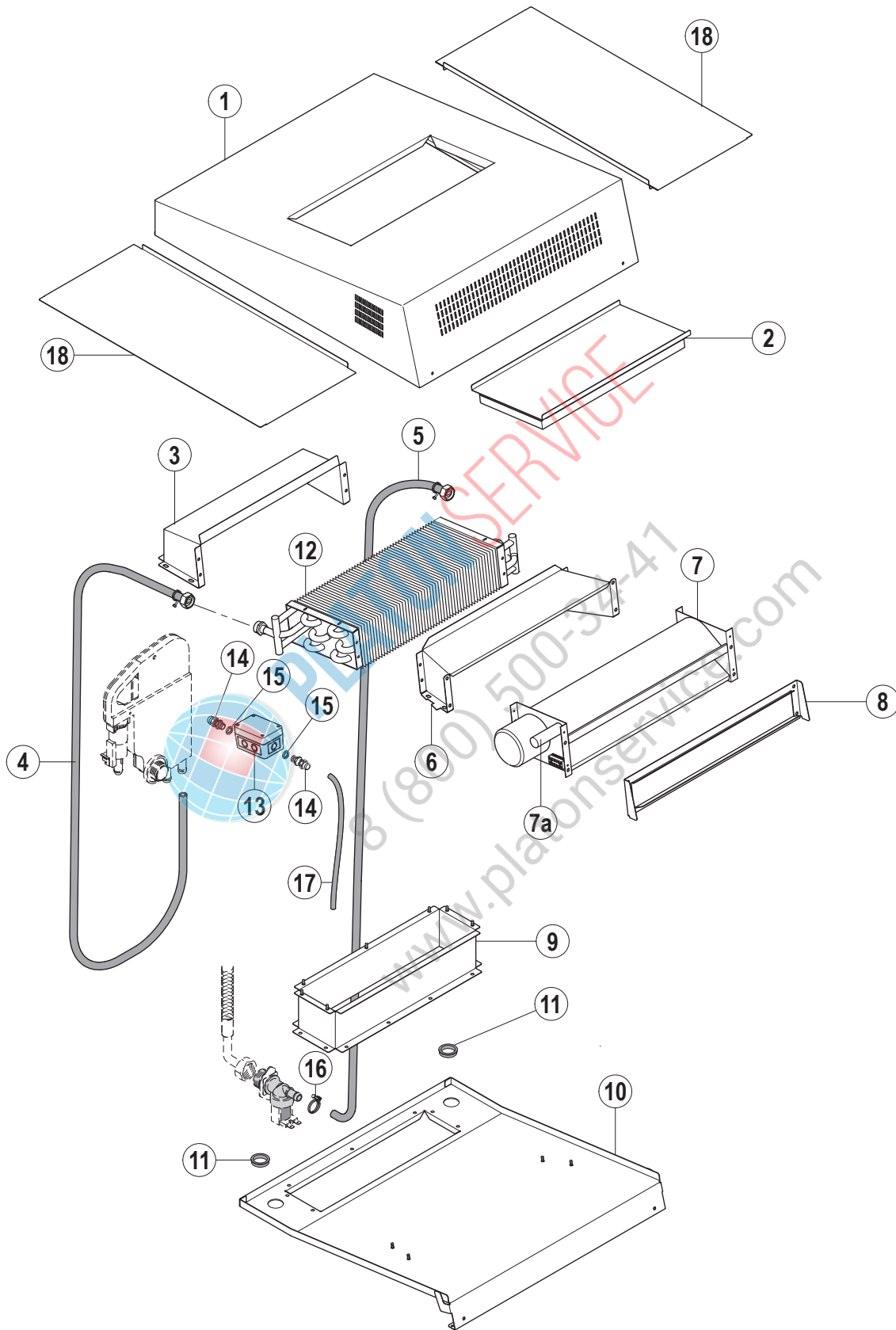

Pos.-Nr. Key no. Réf.	Teile-Nr. Part no. No. pièce	Teile-Benennung Part name Nom de la pièce	Bemerkungen Remarks Remarques
01	01-294633-001	Verkleidung Cover Couvercle	
02	01-294723-001	Deckel Cap Bouchon	
03	01-294626-001	Absaugkanal Suction Aspiration	
04	01-294971-001	Schlauch Hose Tuyau	
05	01-294970-002	Schlauch Hose Tuyau	
06	01-294628-001	Absaugkanal Suction Aspiration	
07	01-294642-001	Querstromventilator Cross flow fan Ventilateur	
07a	01-294642-011	Kondensator Condenser Condensateur	
08	01-294753-001	Umlenblech Baffle Déflecteur	
09	01-294683-002	Absaugkanal Suction Aspiration	
10	01-294698-001	Befestigung Attachment Attachement	
11	00-886756-002	Kabeldurchführung Cable duct Passe fil	
12	01-294624-001	Kondensator Condenser Condensateur	
13	01-294972-001	Abzweigdose Socket Prise	
14	00-695661-002	Kabelverschraubung Cable gland Passe de câble	
15	00-695664-002	Mutter Nut Ecrou	
16	00-323945-018	Schlauchklemme Hose clamp Collier de tuyau	

Pos.-Nr. Key no. Réf.	Teile-Nr. Part no. No. pièce	Teile-Benennung Part name Nom de la pièce	Bemerkungen Remarks Remarques
17	01-294719-001	Kabel Cable Câble	
18	01-294722-001	Abdeckung Cover Couvercle	



PLATON SERVICE

8 (800) 500-34-47

www.platonservice.com



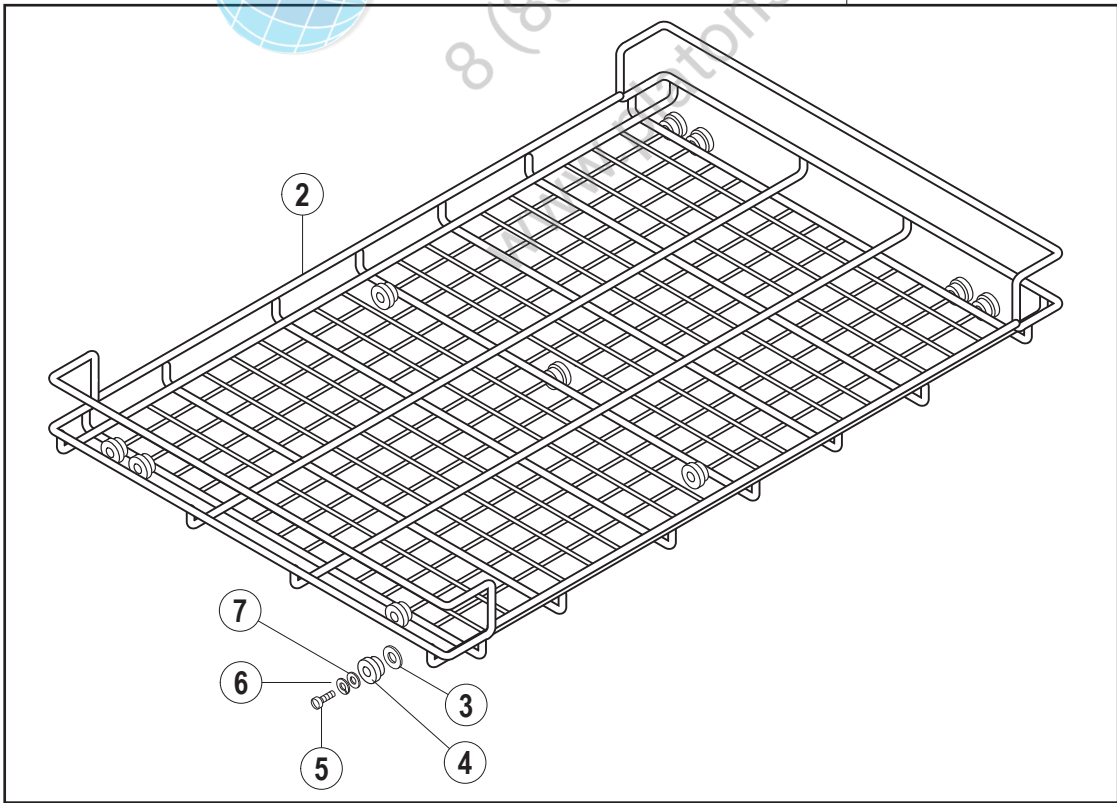
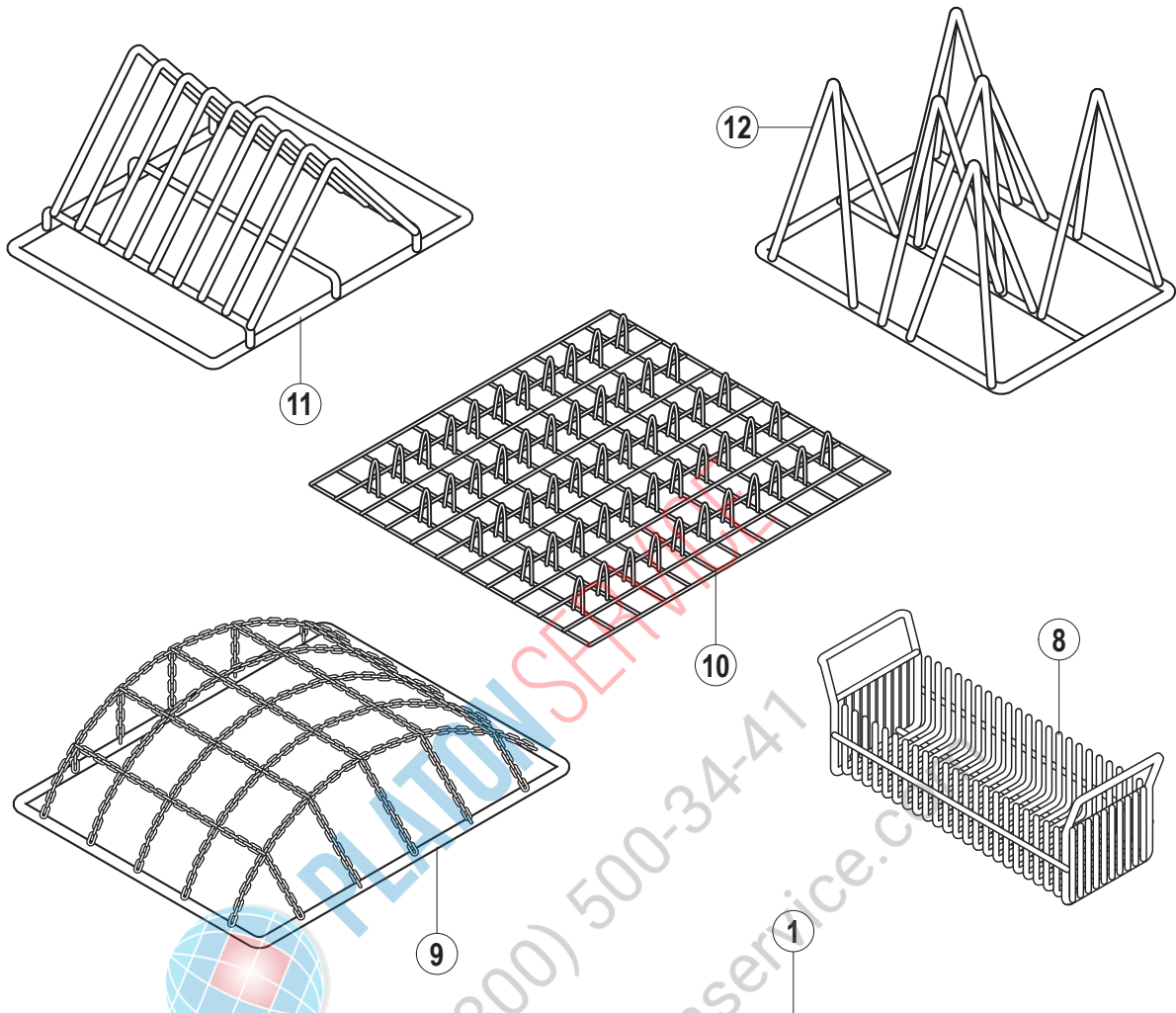

Pos.-Nr. Key no. Réf.	Teile-Nr. Part no. No. pièce	Teile-Benennung Part name Nom de la pièce	Bemerkungen Remarks Remarques
01	00-323741-000	Universalkorb, kpl. Universal rack, assy Panier universel, cpl.	
02	00-323742-000	Universalkorb Universal rack Panier universel	
03	00-602287-000	Scheibe Washer Rondelle	
04	00-323743-000	Rolle Roller Roue	
05	00-602691-000	Schraube Screw Vis	
06	00-602308-000	Federring Spring washer Rondelle élastique	
07	00-602283-000	Scheibe Washer Rondelle	
08	00-323641-000	Besteckkorb Cuttlery rack Panier à couverts	
09	00-323777-000	Kettenrahmen Chain frame Cadre de chain	
10	00-323753-000	Korbeinsatz Rack insert Garniture de panier	
11	00-323637-000	Korbeinsatz Rack insert Garniture de panier	
12	00-323638-000	Korbeinsatz Rack insert Garniture de panier	



HOBART behält sich das Recht vor, an allen Produkten technische Änderungen und Verbesserungen ohne Ankündigung vorzunehmen.

As continued product improvement is a policy of HOBART, specifications are subject to change without notice.

Ce catalogue n'est pas contractuel. HOBART se réserve le droit, et sans préavis, d'apporter toutes modifications ou améliorations à ses matériels.